

Rev. 02/2023

SERIE 3939 MP2 BIG

Self-cleaning magnetic sludge remover filter.

SERIE 3939 MP2 BIG

Self-cleaning magnetic sludge remover filter.

- +** Removes any impurity
- Excellent hydraulic properties
- Installation on piping VERTICAL – HORIZONTAL –DIAGONAL
- Extends boiler lifespan
- Fights corrosion
- Ensures system efficiency
- Complete with shut-off device

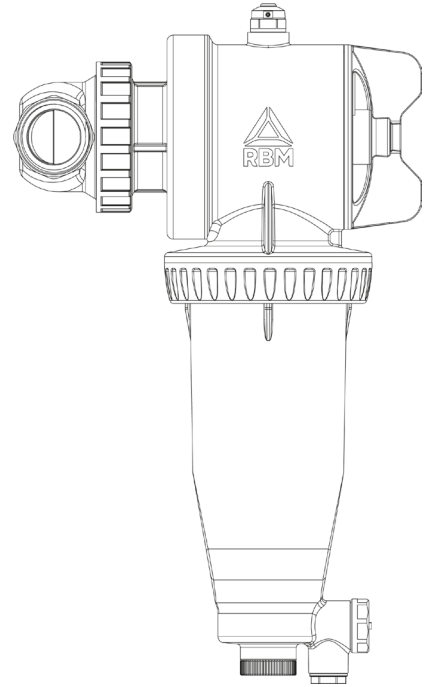

PRODUCTION RANGE

	Code	Size	Connection	Diverter valve body
	3939.06.00	1"	FF UNI-EN-ISO 228	Brass

DESCRIPTION

MP2 BIG, multifunction magnetic sludge remover filter by RBM represents the best solution to solve plant problems due to particle presence, especially rust and sand that are formed due to corrosion and scale during the normal operation of a system. In addition to being installed on household boilers, MP2 is particularly suitable for protecting the heat pumps used in domestic systems. The integrated double shut-off device greatly reduces installation space (without two ball valves)

OPERATING PRINCIPLE

Through its effective and constant action, the magnetic filter collects all the impurities present in the system, preventing them from circulating within it, thus avoiding wear and damage of the rest of the system components, but above all constantly protecting the boiler

USE

It is advised to install **MP2 BIG** on the inlet circuit of the heat pump, in order to protect it from any impurities in the system, especially during the start-up phase.

It is important to follow the direction indicated by the ARROW on the body to ensure better performance of the filtering action. The jointed part allows installation on the following types of pipes:

- VERTICAL
- HORIZONTAL
- DIAGONAL

Thanks to its jointed seal and to the presence of an opening cap, **MP2 BIG** is suitable to easily add chemicals for the treatment of the system.

CONSTRUCTION FEATURES

Diverter valve body:	Nickel-plated brass
Cartridge body:	Plastic polymer
Locking ring nut:	Plastic polymer
Locking ring nut:	Plastic polymer
Filtering cartridge:	AISI 304
Hydraulic seals:	EPDM
Magnet:	Neodymium REN35 B = 11.000 Gauss
B (MaxT) / B (RoomT)* < 1% (where MaxT = 130°C, RoomT = 21 °C) Tested according to IEC 60404-5 & ASTM A977 regulations	

TECHNICAL FEATURES

Compatible fluid:	Water, Water + Glycol
Max. operating pressure:	6 Bar
Operating temperature:	0 ÷ +70 °C
Max T (one hour max):	90 °C

DIMENSIONAL FEATURES

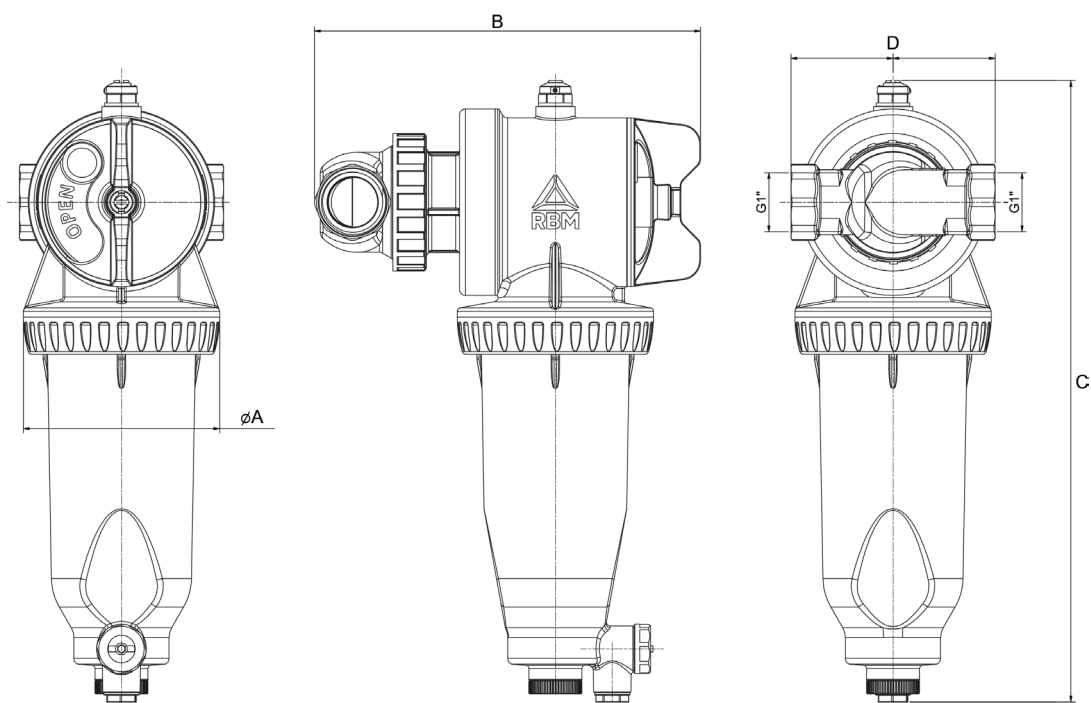

Code	G	A [mm]	B [mm]	C [mm]	D [mm]
3939.06.00	1"	100	196	316	104

FLUID DYNAMICS FEATURES

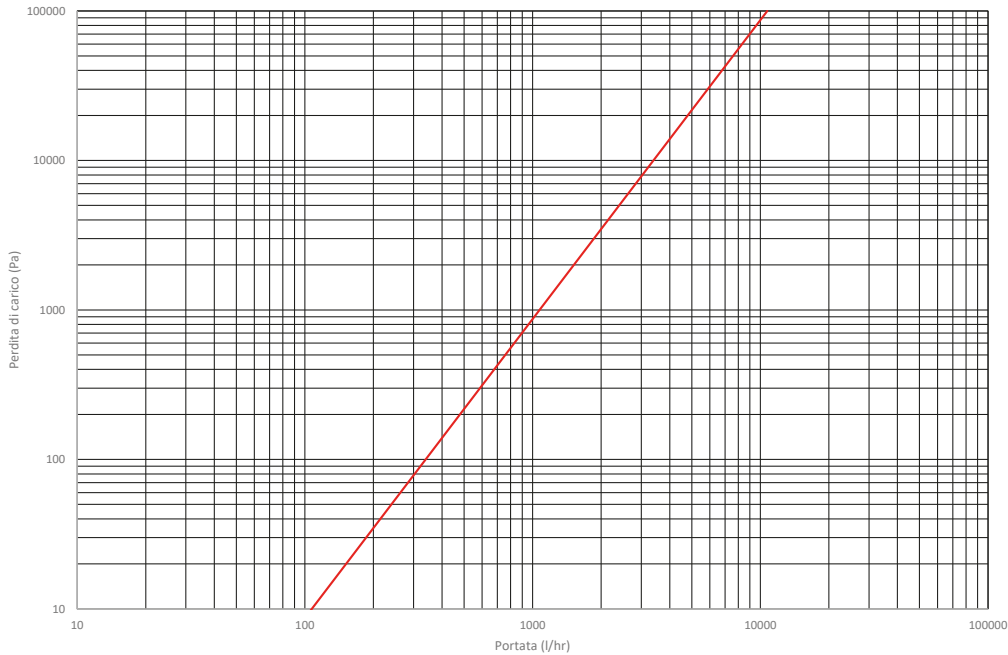

Size	Kv [m ³ /h]
1"	10.73

OPERATING PRINCIPLE

By going through a set course, the fluid is forced to cross the mesh of the cartridge and enter the filtering chamber.

In this filtering chamber, thanks to the simultaneous action of the:

- filtering cartridge
- magnet
- direction of the fluid given by the specific internal geometry in the different phases, water is filtered.

First of all, the sudden cross-section variation (the filtering chamber has a much greater diameter than the conduit) slows down the fluid motion and, consequently, the entrainment rate of the particles suspended in it.

The particles pass inside the filtering cartridge and are directly filtered. The heavier particles fall downwards due to gravity, which prevails over the drag force.

In this way, all magnetic (ferrous residues) and non-magnetic (algae, sludge, sand, ...) contaminants in the system are retained in the filtering chamber.

La cartuccia in acciaio inox nel modello base ha una filtrazione di 800 micron.

The shut-off device must be used when cleaning the filter after having switched off the pump. It is built into the device and is operationally equivalent to 2 ball valves (filter inlet and filter outlet). When the shut-off device is closed, the impurity collection chamber is excluded. A small amount of fluid continues to circulate in bypass in the diverter valve which is why it is important to switch off the pump before performing maintenance.

SHUT-OFF DEVICE

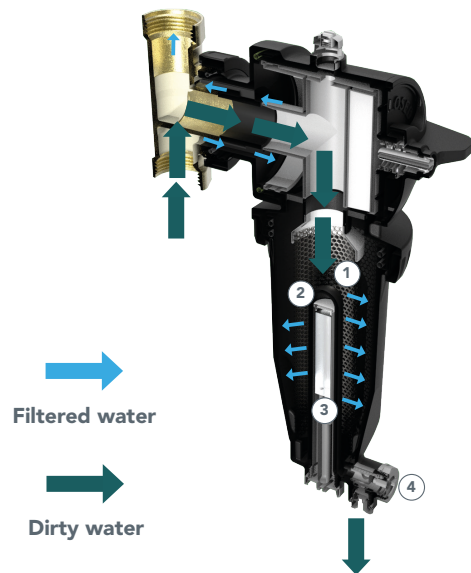

- ① Filtering cartridge
- ② Filtering chamber
- ③ Removable magnet
- ④ Exhaust valve

INSTALLATION

It is advised to install the multifunction magnetic sludge separator on the circuit, at the inlet of the boiler or heat pump, in order to protect it from any impurities in the system, especially during the start-up phase.

It is important to follow the direction indicated by the ARROW on the body to ensure better performance of the filtering action. The multifunction magnetic sludge separator must be installed with the main cartridge/magnet body facing downwards.

The jointed part allows installation on the following types of pipes: VERTICAL, HORIZONTAL and DIAGONAL.

The sealing between the jointed part and the rest of the body does not depend on the strength with which the adjustment ring nut is tightened. This because it is a telescopic sealing, and not a head sealing.

The top part of the filter is provided with a female G 1/4" connection with air venting valve.

This can be used to continuously eliminate air not ejected during the filling phase.

HORIZONTAL MOUNTING

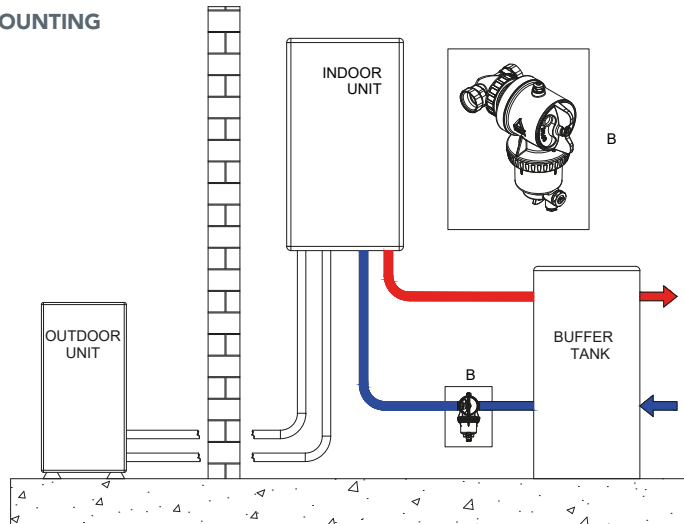

VERTICAL MOUNTING

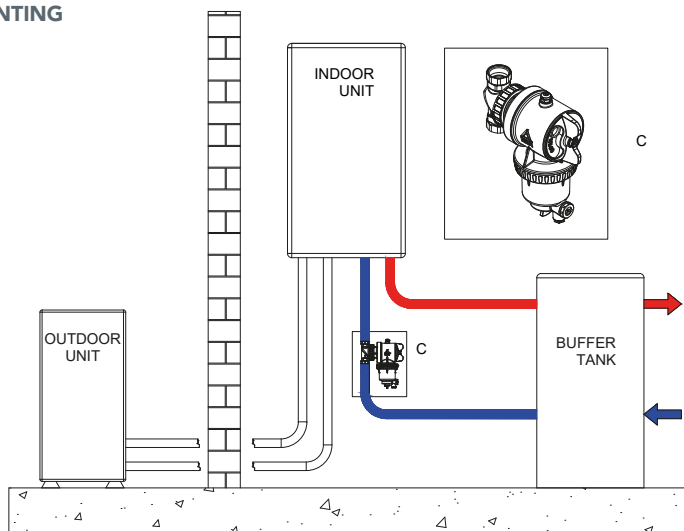

MAINTENANCE INTERVENTION WITHOUT DISASSEMBLING THE FILTER

It is possible to clean the cartridge by extracting the magnet or, alternatively, by completely unscrewing the cartridge support/magnet.

Before cleaning **MP2 BIG**, ensure the working environment is safe. **RBM recommends that the pump be off and the system be allowed to cool at room temperature before carrying out any maintenance intervention, in order to avoid burns.**

1



Turn off the pump. Unscrew the drain plug.

2



Open the exhaust valve to depressurise the system (5 seconds) and close it again. Use a container to collect drain water

3



Close the filter by rotating the knob..

4



Unscrew the magnet and remove it. Place the magnet on a clean surface.

5



Open the drain. The dirt inside the filter no longer captured by the magnet will be channelled outside by the flow of water in the drain. Use a container of at least 0.5 L

6



1. Close the drain.
2 Put the grey safety plug back on.
3. Put the magnet back on.
4. Turn the knob to open.
5. Start the pump.

MAINTENANCE INTERVENTION DISASSEMBLING THE FILTER

It is possible to clean the cartridge by extracting the magnet or, alternatively, by completely unscrewing the cartridge support/magnet.

Before cleaning **MP2 BIG**, ensure the working environment is safe. **RBM recommends that the pump be off and the system be allowed to cool at room temperature before carrying out any maintenance intervention, in order to avoid burns.**

1



Turn off the pump. Unscrew the drain plug.

2



Open the exhaust valve To depressurise the system. (5 Seconds) and close it again. Use a container to collect drain water

3



Close the filter by rotating the knob

4



Open the drain and empty the water inside it. Use a container of at least 1 l.

5



Unscrew the ring nut. Release the body.

Remove the magnet (put it back in a clean place).

Remove the stainless steel cartridge. Wash the body and cartridge under running water.

6



1 Close the drain.
2 Put the grey safety plug back on. 3 Put the magnet back on.
4. Turn the knob to open.
5. Start the pump.

RBM spa reserves the right to improve and change the products described and relevant technical data at any moment and without prior notice. The information and pictures contained in this document are intended for information purposes only, are not binding and do not exempt the user in any case from strictly following the regulations in force and good practice standards.