

Rev. 05/2019

FAN COIL UNIT KIT

FAN COIL UNIT KIT

- +
 - Ensures system efficiency
 - Provides dynamic balancing and flow control
 - Provides flushing by-pass
 - Ensures easy commissioning throughout several P/T points
 - Provides fast draining and direct filtering

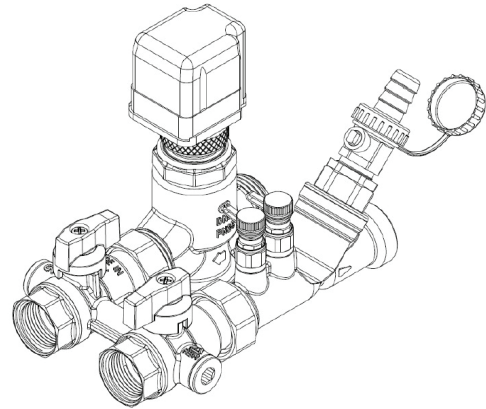

PRODUCTS RANGE

Code	Size	Max recommended flow rate for a proper flow reading with RBM Venturi System		Connections
		l/s	L/hr	
3717.05.00	3/4"	0,111	400	F UNI-EN-ISO 228
3717.05.10	3/4"	0,194	700	F UNI-EN-ISO 228
3717.05.20	3/4"	0,361 ^(*)	1300 ^(*)	F UNI-EN-ISO 228

^(*) this value is the max flow that could be detected with the Venturi. FCU is limited by the PICV flow range (see dedicated section)

DESCRIPTION

THE PURPOSE

The **RBM Fan Coil Unit** is a valve system that combines the pressure independent control valve with isolation, flushing, draining and commissioning components into a prefabricated tested and ready to install terminal bypass unit.

The RBM Fan Coil Unit is supplied with an integral venturi metering station which can be used for flow verification, which is a required feature by design guidelines from BSRIA for terminal unit.

The unit is supplied with:

- isolation valves
- strainer
- draining point
- P/T plugs
- integrated venturi metering station
- PICV valve for flow, temperature and pressure control

USE

RBM Fan Coil Unit is designed for direct mounting to terminal units in heating and cooling applications, please see the "USE / INSTALLATION" section of this data sheet.

CONSTRUCTION FEATURES

Body:	DZR Brass EN12165 CW 602N
PICV	
Flushing by-pass valve	
Strainer and draining combi valve	
Strainer basket:	800 µm, AISI 302 stainless steel
Seats:	EPDM + Perox
Connections:	F UNI-EN-ISO-228 connections

TECHNICAL FEATURES

Max. static working pressure	25 bar
Max. differential pressure	4 bar (400 kPa)
Max. flow temperature	120 °C
Min flow temperature	-10 °C

DIMENSIONAL FEATURES

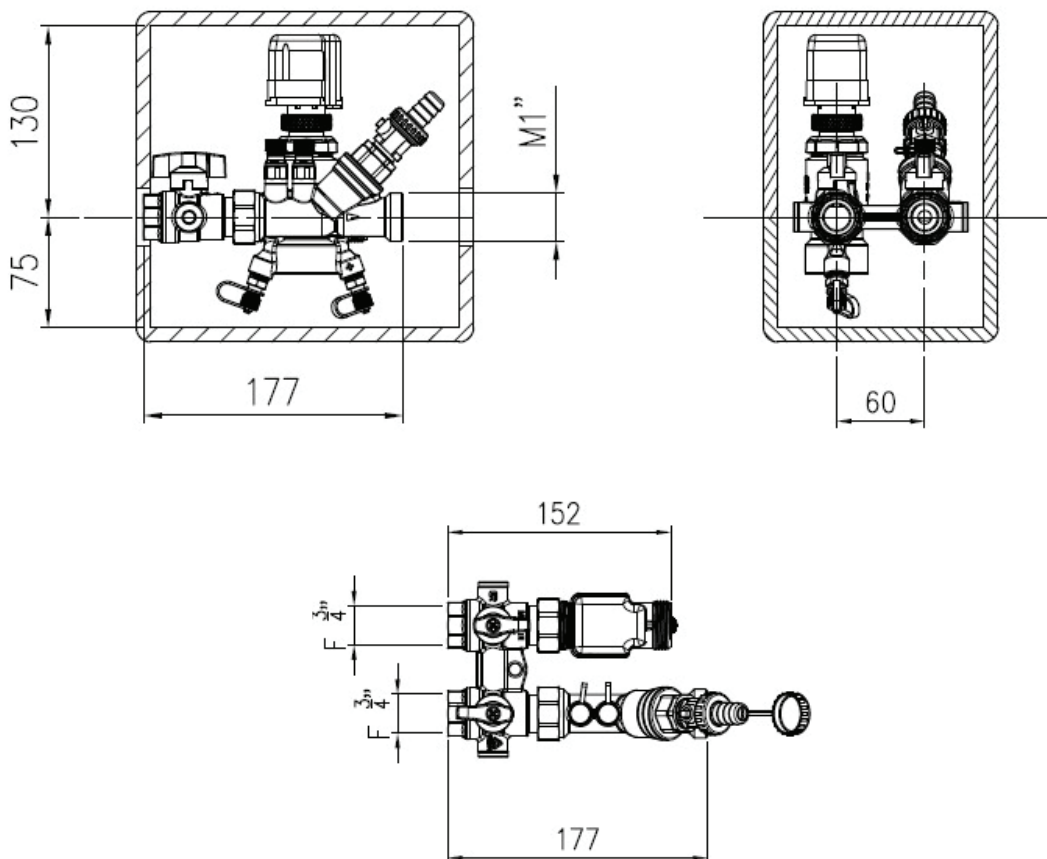

STRENGTHS / WORKING PRINCIPLE

The BSRIA guide to Energy Efficient Pumping Systems BG 12 / 2011 clearly indicates that significant energy savings can be made by utilizing Pressure Independent Control Valves (PICV) on terminal units in Variable Volume Systems.

The **RBM Fan Coil Unit** allows pressure independent control ensuring full stroke vs pressure fluctuation (which means 100% authority in control the terminal unit and guarantee as well constant flow rate maximising energy efficiency for the system). The **RBM Fan Coil Unit** can be used also for flushing and isolating operations at whatever of commissioning and maintenance stage. The unit can be used for both heating and cooling so this means there is no product differentiation between both functioning modes. The drain point with built-in cock fitted to the strainer allows flushing without the need to remove

the strainer basket allowing this last to be easily cleaned. The RBM features and benefits are:

- DN20 version designed with 60 mm centres
- Allows regulating, balancing flushing and isolating operations
- Flushing bypass included as recommended by BSRIA BG29/2011
- Fully assembled and tested at the factory
- All components made in DZR Brass
- Optimize time and installation cost (5 valves in one)
- Fast connection (only four connections are required)
- SS flexible pipes supplied for easy connection to the terminal unit and system if required

FLUID DYNAMICS FEATURES

Flow rate diagram for RBM Venturi System

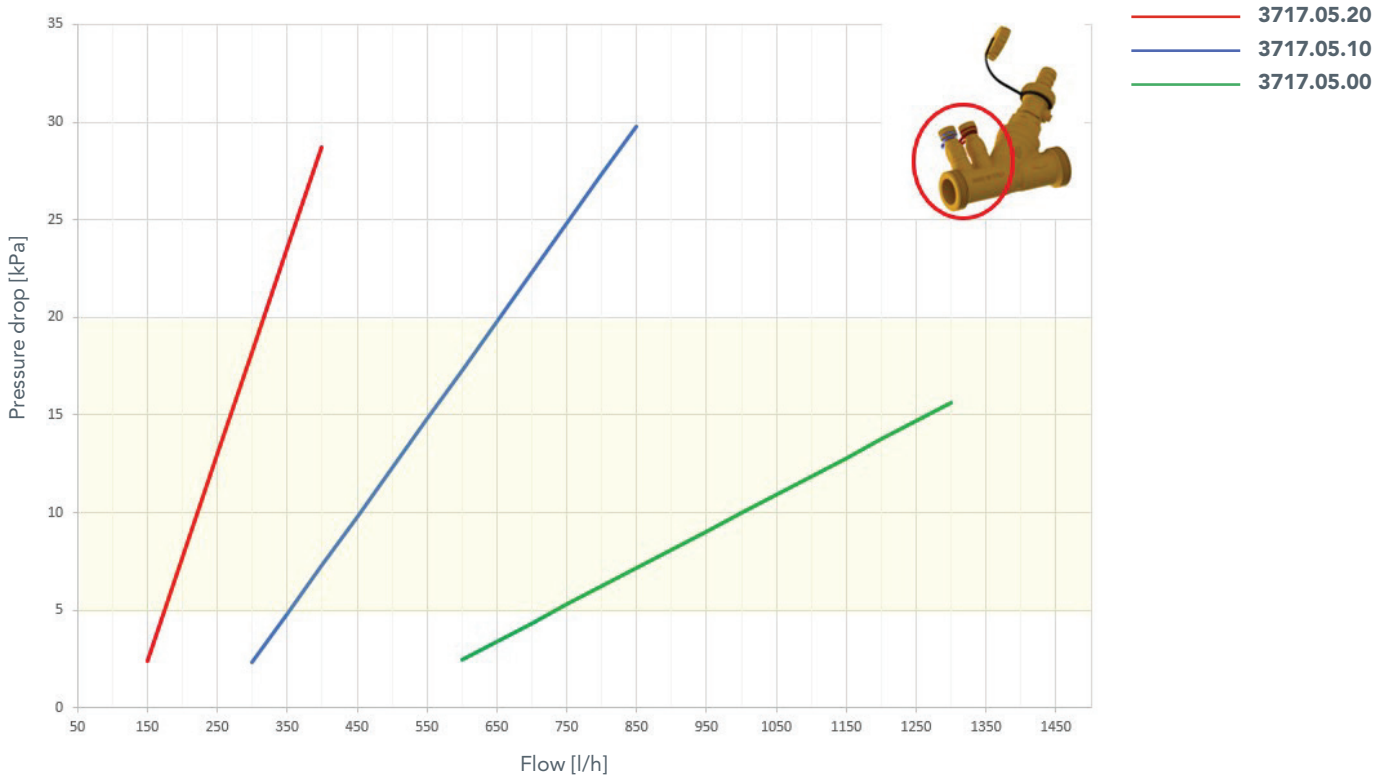

Product Code	Min Flow		Max Flow	
	l/s	l/hr	l/s	l/hr
3717.05.00	0,055	200	0,111	400
3717.05.10	0,111	400	0,194	700
3717.05.20	0,194	700	0,361 (*)	1300 (*)

(*) this value is the max flow that could be detected with the Venturi in normal operating condition. FCU is limited by the PICV flow range (see dedicated section)

It is recommended to select the FCU within the application and preset the PICV as required in order to allow the Venturi system to work within the minimum and maximum operating ΔP conditions able to respond with the design flow values. The table below shows the flow rates to meet the recommended criteria of use in commissioning stage the Venturi System of the FCU. Flow

values higher than the maximum specified may results in increasing of pressure drops as well as not proper reading of the flow through the Venturi. However, to avoid misfunction or noise do not work out of the specified region. temporary working conditions outside those specified are tolerated under penalty of inefficient operation of the FCU.

PICV CHARACTERISTICS

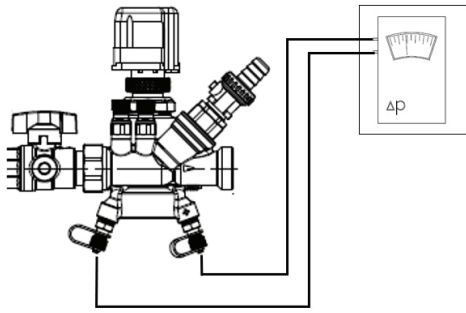

$$\Delta P \geq \Delta P_{\min} \rightarrow Q = Q_{\text{nom}}$$

$$\Delta P < \Delta P_{\min} \rightarrow Q = Kvs \sqrt{\Delta P}$$

Pre-Set	Flow Rate			Min ΔP kPa	Kvs
	l/h	l/s	GPM		
1.0	150	0,042	0,66	18	0,35
1.2	200	0,056	0,88	18	0,47
1.4	244	0,068	1,07	18,5	0,57
1.6	259	0,072	1,14	18,5	0,60
1.8	273	0,076	1,20	19	0,63
2.0	315	0,088	1,39	19	0,72
2.0	315	0,088	1,39	19	0,72
2.2	350	0,097	1,54	19	0,80
2.4	370	0,103	1,63	19	0,85
2.6	380	0,106	1,67	19	0,87
2.8	390	0,108	1,72	19	0,89
3.0	425	0,118	1,87	19	0,98
3.0	425	0,118	1,87	19	0,98
3.2	456	0,127	2,01	20	1,02
3.4	475	0,132	2,09	20	1,06
3.6	502	0,139	2,21	21	1,10
3.8	545	0,151	2,40	21	1,19
4.0	590	0,164	2,62	23	1,23
4.0	590	0,164	2,62	23	1,23
4.2	610	0,169	2,69	23	1,27
4.4	690	0,192	3,04	24	1,41
4.6	812	0,226	3,58	25	1,62
4.8	885	0,246	3,90	26	1,74
5.0	900	0,250	3,96	26	1,77

USE / INSTALLATION AND BALANCING PROCEDURE

Before installation of RBM FCU kit check that inside the PICV valve and the pipes there are no foreign matters which might damage the tightness of the valve. Make sure that required flow rate is within operating range of the valve. Valves may be installed either on horizontal or vertical pipelines with the electric actuator faced-up and following the arrow direction casted on the valve body, which shall be the same as the flow one. For assembly purposes, use a spanner, not a pipe wrench, by applying necessary working torque. The PICV valve built in in the FCU unit is supplied with a cap allowing (when screwed) the manual closing of the valve.

Take the plastic cap screwed on the upper part of the valve off. Turn the presetting dial device (see picture) and match the mark on the swivel part with the value stated on the fixed part of said device (1, 2, 3, etc.), which shall correspond to required flow rate. Do not exceed the working setting range (1-5). The relation between flow rate and values shown on the presetting dial device are given by the table stated above. Using the differential manometer check that the differential pressure is higher or the same as the minimum value reported in said table. The differential manometer inter-faces with the balancing valve through the two binder points of the valve. When balancing is achieved, screw the lock for presetting dial completely, preventing any unintentional rotation.

After the PICV has been preset at the required flow value use the manometer to also check the flow trough the RBM FCU using the two binder points pre-fabricated into the Venturi system (see relative section).

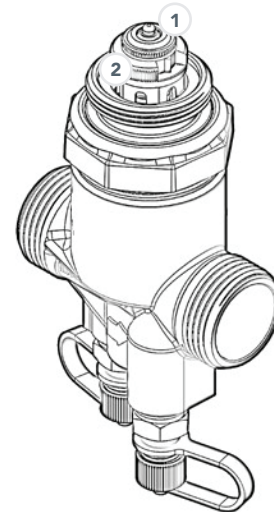

BALANCING

- 1 Lock for presetting dial
- 2 Presetting dial

APPLICATION DIAGRAMS

The RBM Fan Coil Unit is suitable for variable volume system to control fan coil flow rate directly. Below a typical installation: in each moment the flow rate is the required one and there will be no extra-flow due to the pressure fluctuations.

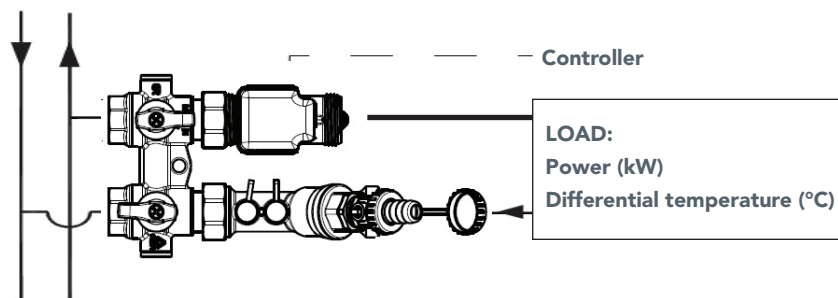

COMMISSIONING AND MAINTENANCE

A.

Use the differential manometer to measure the overall pressure drop downstream the FCU (e.g. coil unit pressure drop)

B.

Use the differential manometer to check the flow through the Venturi (see relative section)

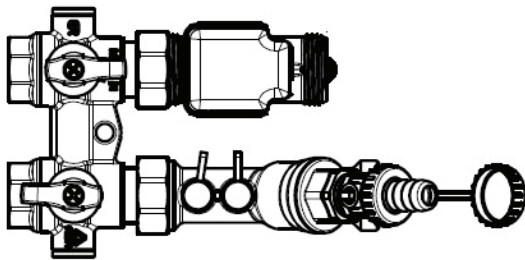
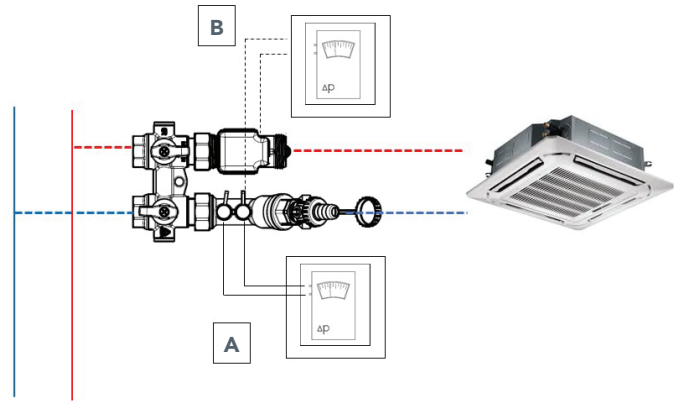

- Shut the PICV gives OFF command to the actuator
- Position the isolation valves in by-pass mode
- Remove the protection cap of the draining valve and mount the hose adapter to use with draining hose pipe (not supply)
- Open the draining valve to clean the strainer

ACTUATORS

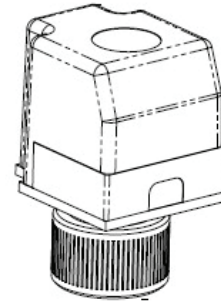
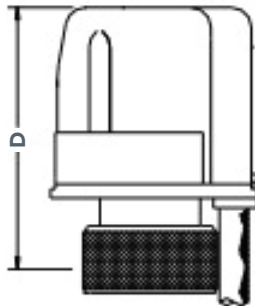
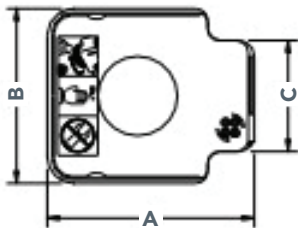

THERMO-ELECTRIC- ACTUATOR (SERIES 3718)

Code	A [mm]	B [mm]	C [mm]
3718-00-22 (*)	52	44	28

(*) look at the table on the side for the actuator technical characteristics

THERMO-ELECTRIC- ACTUATOR (SERIES 3718)

Model:	ON-OFF 230V AC
Code:	3718.00.22
Voltage:	230 VAC
Control:	ON-OFF NC
Frequency:	50/60 Hz
Power:	2.5 W
Closing and opening time:	3 min
Degree/Class of operation:	IP54/II
Actuator stroke:	4.5 mm
Actuating force:	160 N
Cable length:	1 m
Connection:	M30x1.5

Note:

- actuator is provided with fail-safe function
- electromechanical actuator available on request

SPECIFICATION ITEMS

SERIES 3717

Fan coil unit kit. DZR brass body. Pressure Independent Control Valve P float. Flushing by-pass. Combiventu valve (3 in one functions: venturi for flow measurement, strainer and draining). 800 µm, AISI 302 stainless steel trainer basket. EPDM + Perox hydraulic seals. Threaded connections FF UNI-EN-ISO 228). Maximum operating pressure (static) 25 bar. Operating pressure range for PICV (Max. 400 kPa, 4 bar). Max flow of 0,361 l/s (see PICV calibration values). Temperature working range (-10 °C÷120 °C). EPP insulation jacket.

RBM spa si riserva il diritto di apportare miglioramenti e modifiche ai prodotti descritti e ai relativi dati tecnici in qualsiasi momento e senza preavviso. Le informazioni e le immagini contenute nel presente documento si intendono fornite a semplice titolo informativo e non impegnativo e comunque non esentano l'utilizzatore dal seguire scrupolosamente le normative vigenti e le norme di buona tecnica.

RBM Spa

Via S. Giuseppe, 1 • 25075 Nave (Brescia) Italy
Tel 030 2537211 • Fax 030 2531798 • info@rbm.eu • www.rbm.eu

 @rbmspa  RBM S.p.A.  rbm_spa_  Rbm Italia