

	Componenti	Components	Inhalt	nr.
1	Valvola a sfera DN 25 V con calotta	Ball valve DN 25 V with nut	Kugelhahn DN 25 V mit Überwurfmutter	2
2	Raccordo di mandata DN 25 con calotta	Delivery tube DN 25 with nut	Vorlaufanschluss DN 25	1
3	Tronchetto dima DN 25 130 mm	Return tube DN 25 130 mm	Rücklaufanschluss DN 25 130 mm	1
4	Maniglia nera con termometro rosso	Black handle with red thermometer	Hebel schwarz mit thermometer rot	1
5	Maniglia nera con termometro blu	Black handle with blue thermometer	Hebel schwarz mit thermometer blau	1
6	Circolatore	Circulator	Umwälzpumpe	(1)
7	Kit guarnizioni	Gaskets kit	Dichtungenset	1
8	Isolamento in EPP nero	Insulation in black EPP	Isolierung aus schwarzem EPP	1

Il gruppo viene fornito standard con mandata a destra. Per convertire la mandata a sinistra posizionare i componenti del gruppo di miscelazione osservando il disegno sottostante.

The standard unit is supplied with right hand delivery. To obtain left hand delivery change the position of unit component looking the picture below.

Die Gruppe wird vom Werk mit rechtem Vorlauf geliefert. Die Änderung des Vorlaufs nach links wird im unterem Bild beschrieben.

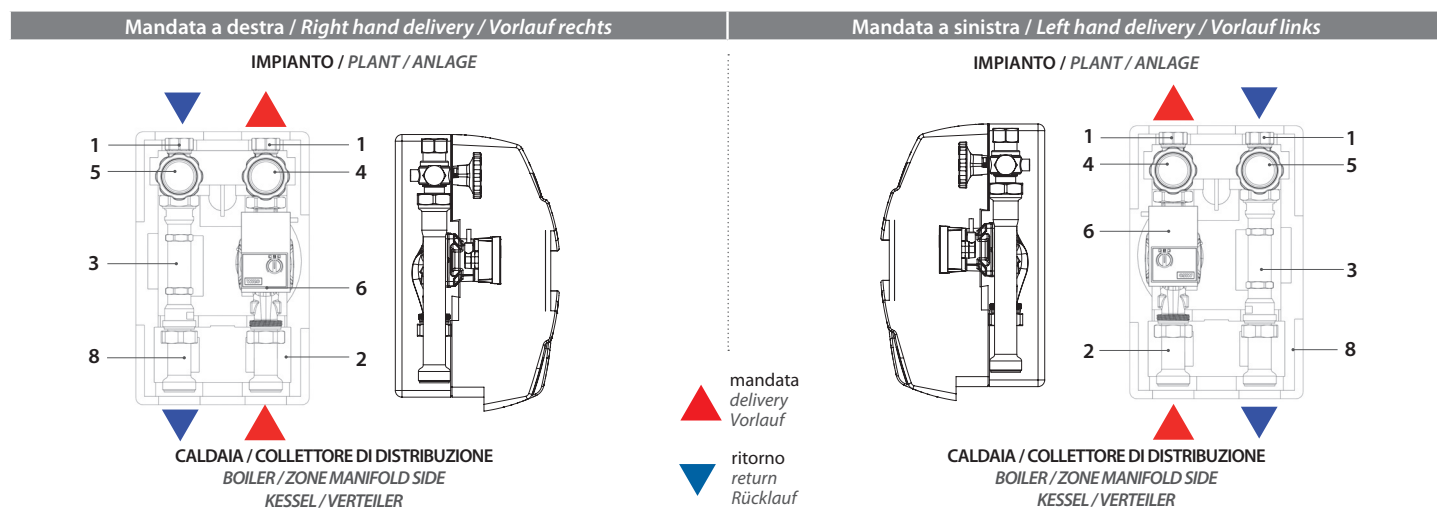

### MODALITÀ RISCALDAMENTO / HEATING / HEIZMODUS



**MODALITÀ RISCALDAMENTO**  
(periodo invernale)  
Con ricircolo d'aria per non surriscaldare eccessivamente i componenti elettrici.

**HEATING MODE**  
(invernal season)  
Air circulating system designed for avoiding the electrical components over heating.

**HEIZMODUS**  
(Winterzeit)  
Ein Lufttauschersystem sorgt dafür, dass die elektrischen Komponenten nicht überhitzen.

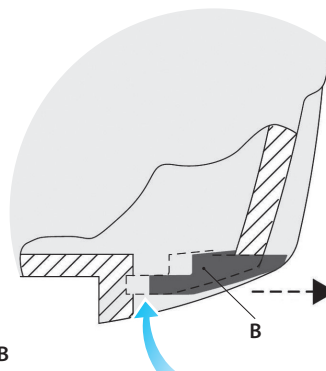
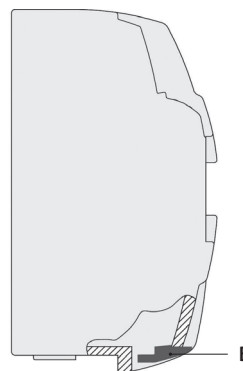
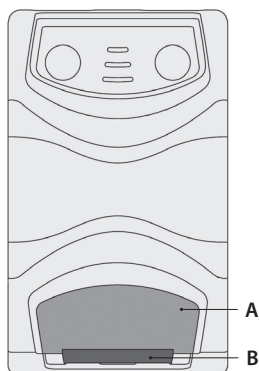

(I) - Collocare il tappo **A** come indicato. Assicurarsi che l'inserto scorrevole **B** sia posizionato come indicato in figura.  
(UK) - Put the **A** tap as indicated. Make sure of the **B** sliding insert is positioned as indicated in the figure.

(D) - Stellen sie Deckel **A** wie angezeigt. Gehen sie sicher, dass sich der Schiebeinsatz **B** in der selben Stellung, wie in der Zeichnung befindet.

### MODALITÀ RAFFRESCAMENTO / COOLING / KÜHLMODUS



**MODALITÀ RAFFRESCAMENTO**  
(periodo estivo)  
Chiusura ermetica con tappi per evitare l'effetto condensa all'interno del modulo.

**COOLING MODE**  
(summer season)  
Hermetic closing system with taps for avoiding the condensation effect inside the unit.

**KÜHLMODUS**  
(Sommerzeit)  
Hermetische Abdichtung des Systems durch Deckel, die Kondensationsschäden im Inneren der Gruppe vermeiden.

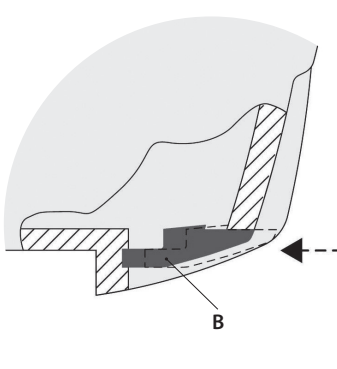
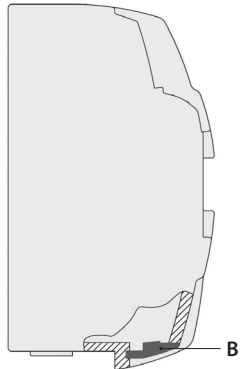
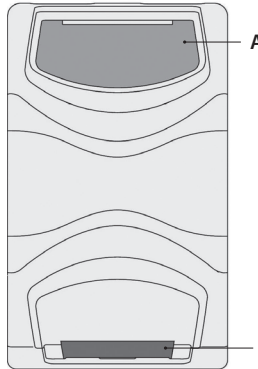

(I) - Rimuovere il tappo **A** e collocarlo come indicato. Assicurarsi che l'inserto scorrevole **B** sia posizionato come indicato in figura.  
(UK) - Remove the **A** tap and place it as indicated. Make sure of the **B** sliding insert is positioned as indicated in the figure.

(D) - Entfernen sie Deckel **A** wie angezeigt. Gehen sie sicher, dass sich der Schiebeinsatz **B** in der selben Stellung, wie in der Zeichnung befindet.