



MP1

Magnetic dirt separator filter for heat exchangers

MP1 RBM is a magnetic sludge remover filter for heat pumps, complete with an integrated shut-off device and a discharge ball cock.

- High performance technopolymer body.
- AISI 304 stainless steel reinforced filtering cartridge.
- Elastomer hydraulic seals.
- Union threaded connections MM UNI-EN-ISO 228.

- Max. operating pressure 6 bar.
- Operating temperature 0 to +90°C
- Neodymium magnet B = 11000 gauss
- Filtering grade 800 µm

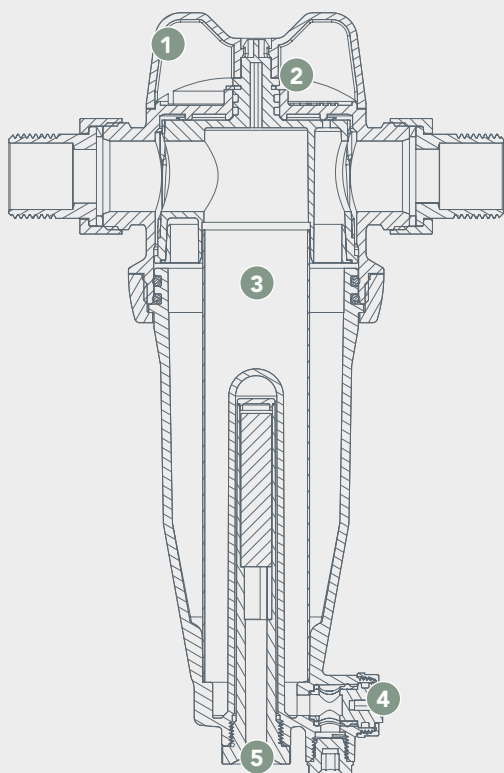

U.S. PATENT FOR INVENTION: N° US11826679B2

- 1 Integrated shut-off device
- 2 Extra connection for temperature and/or pressure probes
- 3 Filtering mesh
- 4 Discharge ball cock
- 5 Removable magnet

FEATURES:

- Very **low pressure** drops;
- Direct filtration with an 800 micron mesh, with other degrees of filtration available (up to 100 micron);
- **Extra connections** for temperature and/or pressure probes;
- Insulation (optional).

Removes any impurity

Self-cleaning

Excellent hydraulic properties

Extends the lifespan of heat pumps

Fights corrosion

Maintains optimum system efficiency

Complete with integrated shut-off device and discharge ball cock.





To Promote the Progress



of Science and Useful Arts

The Director

of the United States Patent and Trademark Office has received an application for a patent for a new and useful invention. The title and description of the invention are enclosed. The requirements of law have been complied with, and it has been determined that a patent on the invention shall be granted under the law.

Therefore, this United States

Patent

grants to the person(s) having title to this patent the right to exclude others from making, using, offering for sale, or selling the invention throughout the United States of America or importing the invention into the United States of America, and if the invention is a process, of the right to exclude others from using, offering for sale or selling throughout the United States of America, products made by that process, for the term set forth in 35 U.S.C. 154(a)(2) or (c)(1), subject to the payment of maintenance fees as provided by 35 U.S.C. 41(b). See the Maintenance Fee Notice on the inside of the cover.



Katherine Kelly Vidal



DIRECTOR OF THE UNITED STATES PATENT AND TRADEMARK OFFICE