



## MP1

### Filtro defangatore magnetico per pompe di calore

**MP1 RBM** è un filtro defangatore magnetico per pompe di calore, completo di dispositivo di intercettazione integrato e rubinetto a sfera di scarico.

- Corpo in tecnopolimero ad alte prestazioni
- Cartuccia filtrante rinforzata acciaio inox AISI 304
- Tenute idrauliche in elastomero
- Attacchi filettati MM UNI-EN-ISO 228 a bocchettone

- Pressione di esercizio max 6 bar
- Temperatura di lavoro 0 ÷ +90 °C
- Magnete al neodimio B = 11000 gauss
- Grado filtrazione 800 µm

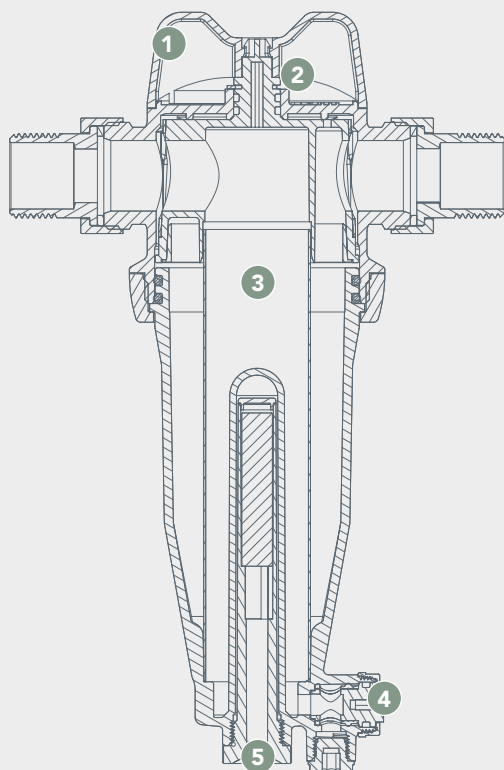

**BREVETTO U.S.A. PER INVENZIONE: N° US11826679B2**

- 1 Dispositivo di intercettazione integrato
- 2 Connessione accessoria per sonde di temperatura e/o pressione
- 3 Maglia filtrante
- 4 Rubinetto a sfera di scarico
- 5 Magnete estraibile

## CARATTERISTICHE

- **Bassissime perdite** di carico
- Filtrazione diretta con **maglia da 800 micron** (disponibili altri gradi di filtrazione, fino a 100 micron)
- **Connessioni accessorie** per sonde di temperatura e/o pressione
- **Coibentazione** (opzionale)

Elimina tutte le impurità

Autopulente

Ottime caratteristiche idrauliche

Prolunga la vita delle pompe di calore

Combatte la corrosione

Garantisce l'efficienza dell'impianto

Completo di dispositivo di intercettazione integrato e rubinetto a sfera di scarico





*To Promote the Progress*



*of Science and Useful Arts*

## *The Director*

*of the United States Patent and Trademark Office has received an application for a patent for a new and useful invention. The title and description of the invention are enclosed. The requirements of law have been complied with, and it has been determined that a patent on the invention shall be granted under the law.*

*Therefore, this United States*

# *Patent*

grants to the person(s) having title to this patent the right to exclude others from making, using, offering for sale, or selling the invention throughout the United States of America or importing the invention into the United States of America, and if the invention is a process, of the right to exclude others from using, offering for sale or selling throughout the United States of America, products made by that process, for the term set forth in 35 U.S.C. 154(a)(2) or (c)(1), subject to the payment of maintenance fees as provided by 35 U.S.C. 41(b). See the Maintenance Fee Notice on the inside of the cover.



*Katherine Kelly Vidal*



DIRECTOR OF THE UNITED STATES PATENT AND TRADEMARK OFFICE