



MG2

Under boiler magnetic sludge remover filter

OPERATING PRINCIPLE

Through its effective and constant action, the magnetic filter collects all the impurities, preventing them from circulating, thus avoiding wear and damage of the rest of the components making up the system, circulators and heat exchangers in particular. **RBM MG2** performs a continuous protective action on the boiler.

USE

It is advised to install **RBM MG2** on the return circuit, at the inlet of the boiler, in order to protect it from any impurities in the system, especially during the start-up phase.

Thanks to its compact dimensions, it can be installed under the boiler, in systems for domestic use, where installation spaces are very limited and there is no room for a traditional dirt separator.

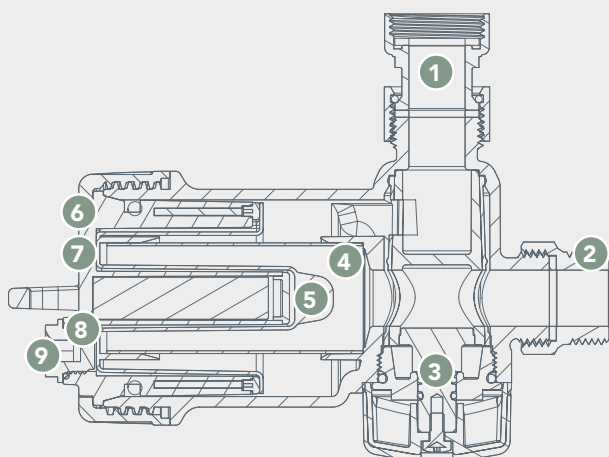

THE SYSTEM WATER IS FILTERED THROUGH THREE ACTIONS:

1. The dirty water is conveyed around the central magnet which attracts the magnetic residues (first magnetic filtration)
2. The water passes through the metal mesh (mechanical filtration of non magnetic impurities)
3. The water touches the external walls of the filter where it meets an 8-magnet crown (second magnetic filtration)

MAXIMUM INSTALLATION VERSATILITY

RBM MG2 can be installed horizontally or vertically, the shank with rotary nut included in the pack is used to connect the boiler and the connection on the circuit can be made with a flexible fitting (accessory 3174.05.30).



VERTICAL ASSEMBLY

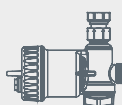

HORIZONTAL ASSEMBLY

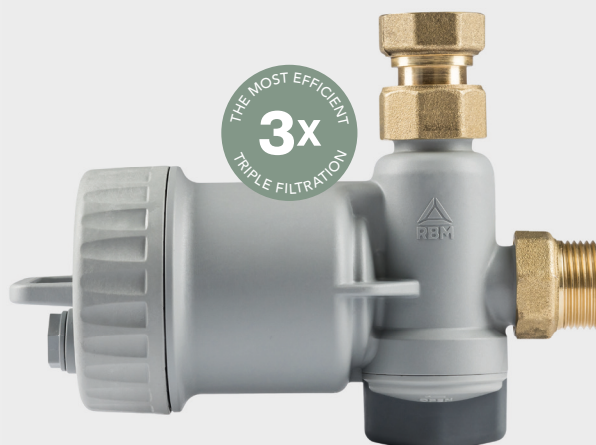

- 1 **Swivel connection**
It enables to easily connect the filter to connection G 3/4" M of the boiler
- 2 **Threaded connections G 3/4"**
Only one type of threaded connections: maximum installation versatility
- 3 **Shut-off system**
During maintenance, it allows to isolate the filter from the delivery and return circuit. This minimises the leakage of already treated water present in the closed circuit
- 4 **Filtering mesh in stainless steel**
- 5 **Magnet protection conduit, removable**
- 6 **Closure**
- 7 **Tightening ring nut**
- 8 **OR di tenuta**
- 9 **Safety drain plug**
Enables to drain the fluid from the main body of the filter and, therefore, to perform programmed cleaning operations

+

- Super compact

- Shut-off system included

- Triplefiltration

- High efficiency

- Removes any impurity

- Fights corrosion

- Increases the lifespan of the boiler

- Ensures system efficiency