

Rev. 10/2017

## **KOMBILUFT**

Safety unit.

# KOMBILUFT

Safety unit.

- + Easy installation and maintenance
- Optimal protection of the heat generator

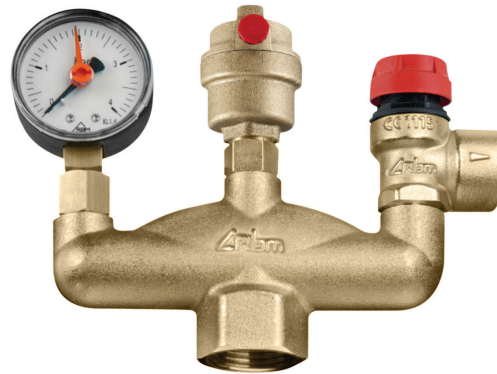

## PRODUCTION RANGE

KOMBILUFT SAFETY UNIT				
Product	Code	Size	Connection	Grade
	47.06.10	G 1"	F UNI-EN-ISO 228	Kombiluft

### DESCRIPTION

Insulated safety unit consisting of:

- Main body in brass with female G 1" connection and three female connections in derivation, of which two G 3/8" and one G 1/2";
- Automatic air venting valve complete with manual closing pawl and check valve. Float operated;
- Standard safety relief valve with controlled rise, male connection 1/2" x female 1/2", orifice diameter 15 mm, discharge capacity max 75 kW, calibration 3 bar;
- Dial pressure gauge Ø50 mm with radial male connection G 1/4", scale 0÷6 bar, complete with check valve.

### THE PURPOSE

The **Kombiluft** safety unit is a unit designed for use in central heating

system for heat generator protection when operating in critical condition.

The pressure gauge assembly complete with check valve allows monitoring the pressure of the heat-carrying fluid.

The float-operated automatic air venting valve allows expelling, without manual intervention, the air that accumulates inside the hydraulic circuit, thus preventing the onset of corrosion and cavitation phenomena in the circulation pumps and the possible formation of air bags in the terminals of the system.

At the same time, the safety relief valve ensures control of system pressure preventing it from rising beyond the allowed limits, discharging into the atmosphere part of the heat-carrying fluid.

## CONSTRUCTION FEATURES

Structure	Brass
Elastomers used	EPDM PEROX and NBR
Float	with lever, made of polypropylene resin
Safety relief valve shutter seal	EPDM PEROX
Safety relief valve membrane	EPDM PEROX
Threaded main connection	F G1" UNI-EN-ISO 228
Safety relief valve drain	F G1/2" UNI-EN-ISO 228

## TECHNICAL FEATURES

Usable fluid	Water + Glycol 30%
Valve seal	3 bar (300 kPa)
Maximum fluid temperature	90 °C
Pressure gauge scale	0...6 bar (0...600 kPa)
Safety relief valve orifice diameter	15 mm
Calibration pressure	3 bar (300 kPa)
Maximum operating pressure	6 bar (600 kPa)
Max bearable pressure	10 bar (1000 kPa)
Max discharge	75 kW

## DIMENSIONAL FEATURES

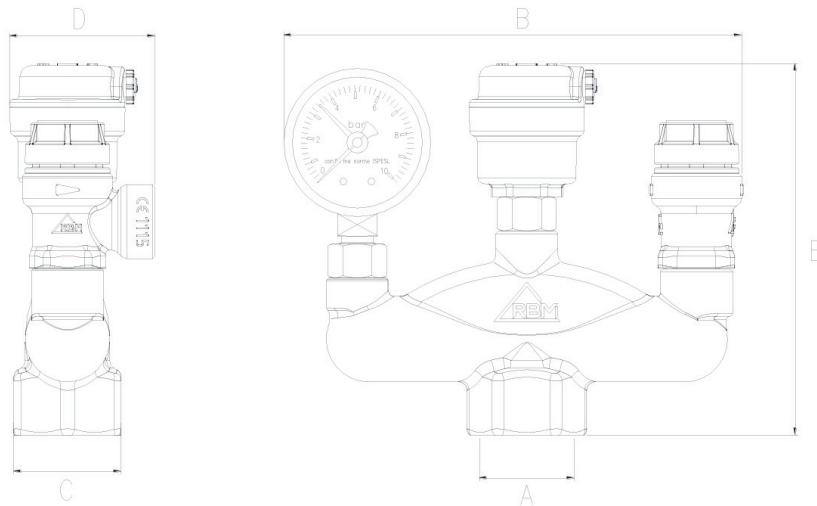

Code	A	B [mm]	C [mm]	D [mm]	E [mm]
47.06.10	G 1"	162	38	51,4	130,5

## SPECIFICATION ITEMS

### SERIES 47

Kombiluft model brass security unit for heating systems, comprising float-operated automatic air venting valve complete with check valve, standard safety relief valve with controlled rise and F G1/2" discharge and dial pressure gauge Ø 50 mm with radial connection complete with check valve.

Safety relief valve calibration 3 bar. Safety relief valve orifice diameter 15 mm. Max temperature 90 °C. Pressure gauge scale 0÷6 bar. Max discharge 75 kW. Size 1".

*RBM spa reserves the right to improve and change the described products and related technical data at any moment and without prior notice: always refer to the instructions attached with the supplied components; this sheet is an aid, should the instructions be extremely schematic. Our technical office is always at your disposal for any doubt, problem or explanation.*