



Rev. 06/2020

LINE FILTER

LINE FILTER



DESCRIPTION

RBM line filters solve plant problems due to pollution from suspended particles with a range of filters suitable for small, medium and large plants.

It should be noted that the line filters are used as an alternative to the self-cleaning filters when it is not necessary to clean them frequently.

The special line filter allows the impurities to be deposited on the bottom of the filter-holder seat, thus facilitating filter maintenance.

PURPOSE

The **line filters** with replaceable filtering cartridge ensure the achievement of the following objectives:

- Easy installation in the hydraulic system;
- Easy maintenance;
- Limited overall dimensions;

This allows them to be inserted in most plumbing and heating hydraulic circuits, preventing damage to adjustment and shut-off cocks and valves from suspended impurities and/or incrustations and sludge already present in the system.

USE

Generally used in plumbing and heating systems, they can be used in all circuits where the transiting fluid is compatible with the construction materials.

The application of the line filters in heating and air conditioning systems correctly prevents the formation of **sludge** caused by the dissociation of the mineral salts contained in thermal fluid and recirculation water.

ASSEMBLY

The filter must be assembled with **the seat-filter holder facing downwards and placed horizontally**, in addition it must be placed inside the circuit **observing the direction of the arrow** stamped on the filter body, which indicates the circuit's direction of flow.

(for further information, refer to what is reported on page 7 of this sheet).

MAINTENANCE

The filter cartridge is made of AISI 304 stainless steel, which can be regenerated, and can be replaced for maintenance or changed with a different rating.

The **line filters** must be subjected to scheduled routine maintenance (cleaning and, if necessary, changing the filtering mesh) at least once a year.

(for further information, refer to what is reported in the "maintenance" section on page 8 of this sheet).

PRODUCTION RANGE

Couplings	Degree of filtration [µm]	Size	FF Code*	MF Code*	Kv [m³/h] ⁽¹⁾
THREADED UNI-EN-ISO 228	800	3/8"	3.03.00	-	2,60
THREADED UNI-EN-ISO 228	800	1/2"	3.04.00	4.04.00	3,40
THREADED UNI-EN-ISO 228	800	3/4"	3.05.00	4.05.00	5,00
THREADED UNI-EN-ISO 228	800	1"	3.06.00	4.06.00	8,70
THREADED UNI-EN-ISO 228	800	1" 1/4	3.07.00	4.07.00	14,10
THREADED UNI-EN-ISO 228	800	1" 1/2	3.08.00	4.08.00	26,50
THREADED UNI-EN-ISO 228	800	2"	3.09.00	4.09.00	26,50
THREADED UNI-EN-ISO 228	800	2" 1/2	3.10.00	-	104,70
THREADED UNI-EN-ISO 228	800	3"	3.11.00	-	108,20
THREADED UNI-EN-ISO 228	800	4"	3.13.00	-	111,80
THREADED UNI-EN-ISO 228	300	3/8"	3.03.10	-	2,00
THREADED UNI-EN-ISO 228	300	1/2"	3.04.10	4.04.10	3,30
THREADED UNI-EN-ISO 228	300	3/4"	3.05.10	4.05.10	4,90
THREADED UNI-EN-ISO 228	300	1"	3.06.10	4.06.10	8,40
THREADED UNI-EN-ISO 228	300	1" 1/4	3.07.10	4.07.10	13,70
THREADED UNI-EN-ISO 228	300	1" 1/2	3.08.10	4.08.10	24,40
THREADED UNI-EN-ISO 228	300	2"	3.09.10	4.09.10	24,40
THREADED UNI-EN-ISO 228	300	2" 1/2	3.10.10	-	100,10
THREADED UNI-EN-ISO 228	300	3"	3.11.10	-	101,70
THREADED UNI-EN-ISO 228	300	4"	3.13.10	-	108,00
THREADED UNI-EN-ISO 228	100	3/8"	3.03.70	-	2,00
THREADED UNI-EN-ISO 228	100	1/2"	3.04.70	4.04.70	3,30
THREADED UNI-EN-ISO 228	100	3/4"	3.05.70	4.05.70	4,90
THREADED UNI-EN-ISO 228	100	1"	3.06.70	4.06.70	8,20
THREADED UNI-EN-ISO 228	100	1" 1/4	3.07.70	4.07.70	13,40
THREADED UNI-EN-ISO 228	100	1" 1/2	3.08.70	4.08.70	23,60
THREADED UNI-EN-ISO 228	100	2"	3.09.70	4.09.70	23,60
THREADED UNI-EN-ISO 228	100	2" 1/2	-	-	-
THREADED UNI-EN-ISO 228	100	3"	-	-	-
THREADED UNI-EN-ISO 228	100	4"	-	-	-
THREADED UNI-EN-ISO 228	50	3/8"	3.03.20	-	1,60
THREADED UNI-EN-ISO 228	50	1/2"	3.04.20	4.04.20	1,90
THREADED UNI-EN-ISO 228	50	3/4"	3.05.20	4.05.20	3,50
THREADED UNI-EN-ISO 228	50	1"	3.06.20	4.06.20	4,30
THREADED UNI-EN-ISO 228	50	1" 1/4	3.07.20	4.07.20	6,60
THREADED UNI-EN-ISO 228	50	1" 1/2	3.08.20	4.08.20	11,20
THREADED UNI-EN-ISO 228	50	2"	3.09.20	4.09.20	11,20
THREADED UNI-EN-ISO 228	50	2" 1/2	3.10.20	-	-
THREADED UNI-EN-ISO 228	50	3"	3.11.20	-	-
THREADED UNI-EN-ISO 228	50	4"	3.13.20	-	-

* **FF:** Female / female connection ** **MF:** Male / female connection

(1) Clean Filter

CONSTRUCTION FEATURES

Body	Nickel Plated Brass CW 617N UNI EN 12165
Nut	Nickel Plated Brass CW 617N UNI EN 12165
Filter	AISI 304 stainless steel (UNI 6900-71)
Gaskets	EPDM PEROX
Threaded connections	UNI-EN-ISO 228

TECHNICAL FEATURES

Max. operating pressure	16 bar (1600 KPa)
Max. operating temperature	100 °C (Water)
Filtration rating	50 ÷ 800 µm
Working fluid	Water

DIMENSIONAL FEATURES

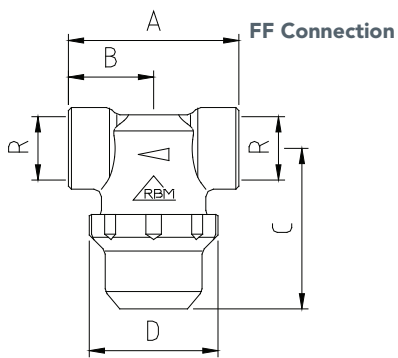

Code	Connection	Size (R)	A [mm]	B [mm]	C [mm]	D [mm]
3.03.X0	FF	3/8"	50	25	51	42
3.04.X0	FF	1/2"	56	28	53,5	42
3.05.X0	FF	3/4"	67	33,5	51,5	47,5
3.06.X0	FF	1"	80	40	55,5	58
3.07.X0	FF	1" 1/4	92	46	68,5	70
3.08.X0	FF	1" 1/2	110	55	93,5	80
3.09.X0	FF	2"	110	55	93,5	80
3.10.X0	FF	2" 1/2	180	90	193	186
3.11.X0	FF	3"	188	94	193	186
3.13.X0	FF	4"	202	101	193	186

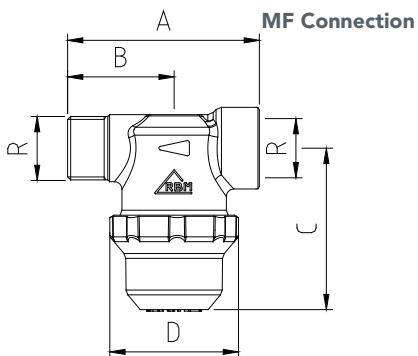

Code	Connection	Size (R)	A [mm]	B [mm]	C [mm]	D [mm]
4.04.X0	MF	1/2"	63	35	53,5	42
4.05.X0	MF	3/4"	72	38,5	51,5	47,5
4.06.X0	MF	1"	87	47	55,5	58
4.07.X0	MF	1" 1/4	97	51	68,5	70
4.08.X0	MF	1" 1/2	115	60	93,5	80
4.09.X0	MF	2"	115	60	93,5	80

FLUID DYNAMICS FEATURES

Analytical procedure for valve dimensioning valid for liquids with $\rho \approx 1 \text{ kg/dm}^3$

$$Kvs = Q \cdot \left(\frac{10000}{\Delta P} \right)^{0,5} \quad \text{valid for water with temp. from 0 to 30 } ^\circ\text{C}$$

Kvs correction for fluids with ρ other than 1 kg/dm^3

$$Kvs' = Kvs \cdot \sqrt{\rho'}$$

Analytical procedure for determining the pressure drop for liquids with $\rho \approx 1 \text{ kg/dm}^3$

$$\Delta P = \left(\frac{Q}{Kvs} \right)^2 \times 10.000 \quad \text{valid for water with temp. from 0 to 30 } ^\circ\text{C}$$

ΔP correction for fluids with ρ different from 1 kg/dm^3

$$\Delta P' = \Delta P \times \rho'$$

KEY

ΔP head loss in daPa (1daPa=10Pa)
 $\Delta P'$ correct head loss in daPa (1daPa=10Pa)
 ΔP_{max} pressure difference recommended for correct operation

Q flow rate in m^3/h
 Kvs hydraulic characteristic in m^3/h
 ρ' liquid density in kg/dm^3

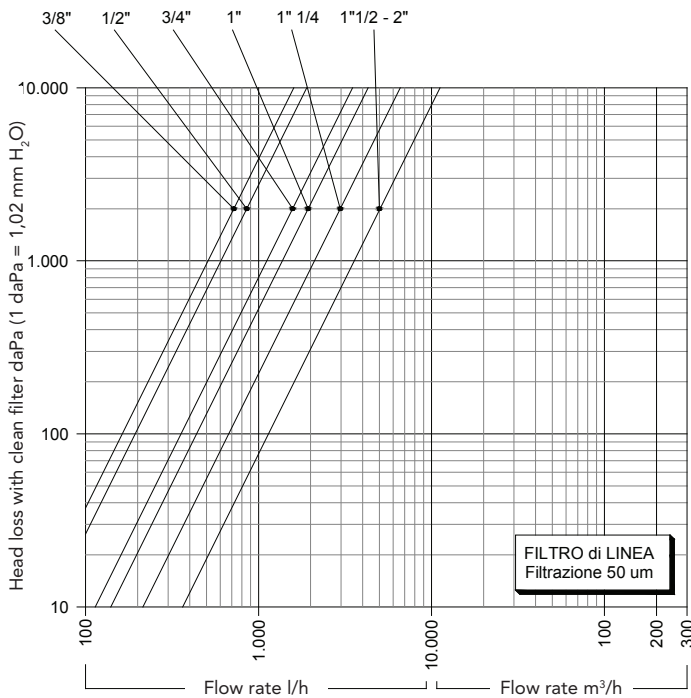

Filtering cartridge 50 [µm]

d	Kvs m^3/h
3/8"	1,60
1/2"	1,90
3/4"	3,50
1"	4,30
1" 1/4	6,60
1" 1/2	11,20
2"	11,20

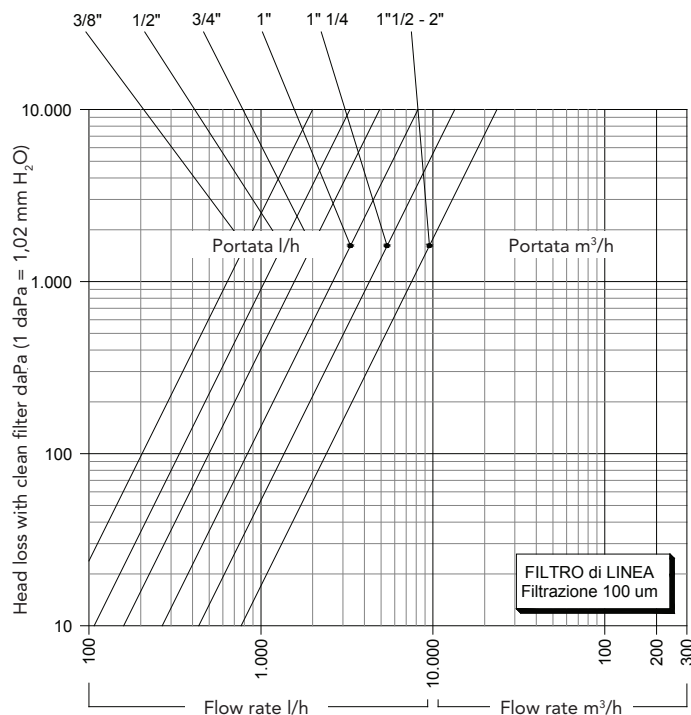

Filtering cartridge 100 [µm]

d	Kvs m^3/h
3/8"	2,00
1/2"	3,30
3/4"	4,90
1"	8,20
1" 1/4	13,40
1" 1/2	23,60
2"	23,60

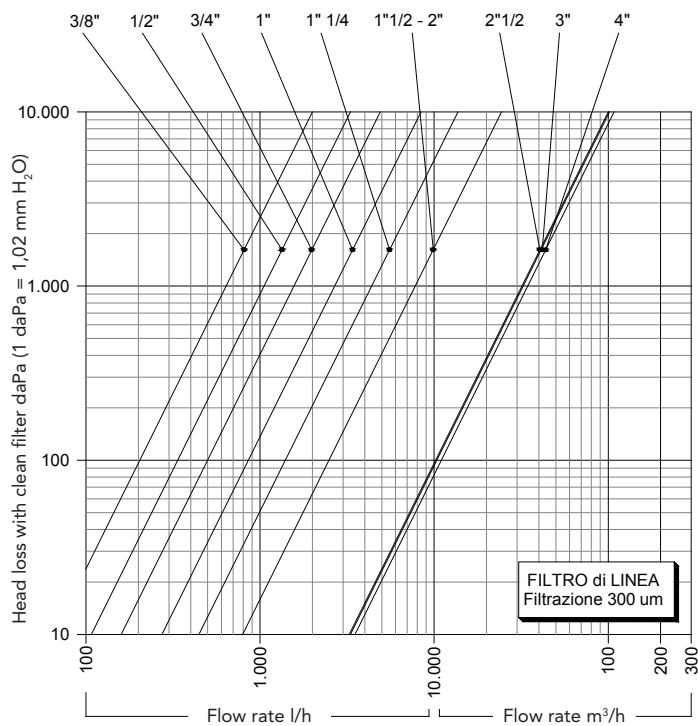

Filtering cartridge 300 [µm]

d	Kvs m³/h
3/8"	2,00
1/2"	3,30
3/4"	4,90
1"	8,40
1" 1/4	13,70
1" 1/2	24,40
2"	24,40
2" 1/2	100,10
3"	101,70
4"	108,00

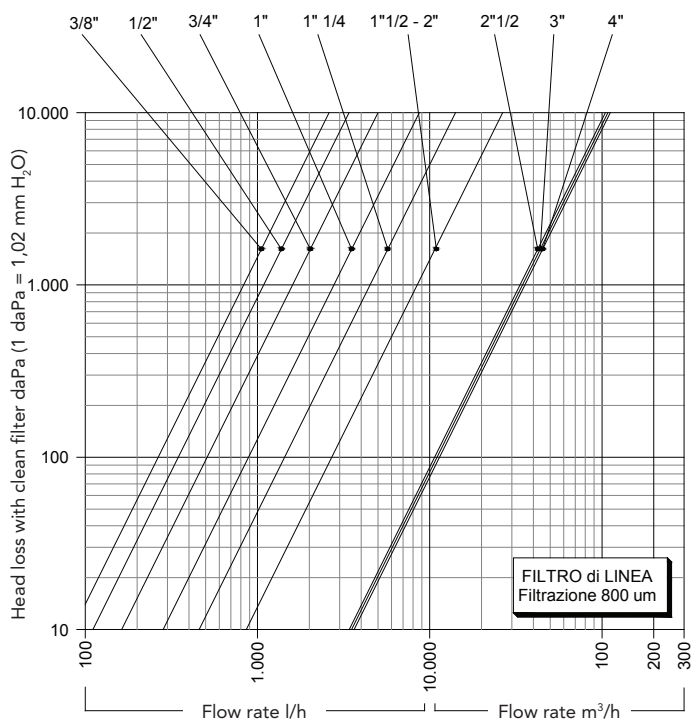

Filtering cartridge 800 [µm]

d	Kvs m³/h
3/8"	2,60
1/2"	3,40
3/4"	5,00
1"	8,70
1" 1/4	14,10
1" 1/2	26,50
2"	26,50
2" 1/2	104,70
3"	108,20
4"	111,80

The specified flow rate values are obtained with **filtering cartridge perfectly clean** and not blocked.

The graphs have the sole purpose of supplying the technician with a quick reference to match the chosen component with a given system size.

Therefore, the values shown are not binding and do not represent the performance limits of the components.

ASSEMBLY / OPERATING PRINCIPLE

The image shows how the RBM line filter must be installed inside a hydraulic circuit.

The filter must be installed **in a horizontal position** with the filter-holder seat facing downwards.

The filter must be placed inside the circuit, observing **the directional arrow** stamped on the filter body, which indicates the circuit's direction of flow.

Always provide a shut-off valve located upstream of the filter to simplify maintenance / cleaning.

Assembly diagram of the purifying filter inside a hydraulic circuit

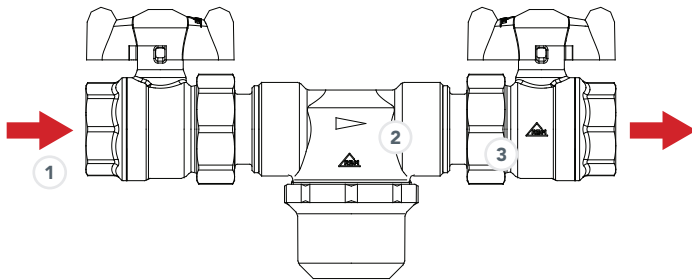

- 1 Direction of water flow
- 2 Directional arrow
- 3 3-piece joint for disassembly

Through a mandatory path the fluid is forced to pass through the mesh of the cartridge where it is cleaned and then made to continue towards the outlet.

The impurities stopped by the filter are accumulated on its bottom.

The filter must be cleaned periodically, as indicated in the "Maintenance" section.

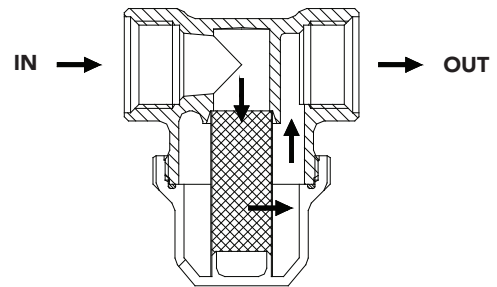

Diagram of water passing through the filter

MAINTENANCE

PRECAUTIONS

For the routine maintenance of the filter and to prevent the emptying of the system, apply shut-off valve (ball valves) in the area of operation.

In the event of installation in flanged systems, provide a pair of RBM PN 16 threaded flanges.

N.B. : It is not essential for the shut-off valves to be in proximity of the filter.

It is sufficient that in any case there are two cocks in a well delimited part of the circuit in order to avoid an excessive outflow of water that could create serious washout problems in the environment.

OPERATIONS

- Bring the containers which must contain the outflow of water as close as possible;
- Close the valves 1-2;

- Unscrew the end plug of the filter, (should high temperature fluid circulate in the circuit, use the necessary precautions and safety devices to avoid direct contact with the fluid).
- Remove the filtering cartridge and open valve 1 briefly; The filtering cartridges must be cleaned with water and vigorous brushing; if damaged, **replace** them (filtering mesh available, between **50** and **800** micron).
- Put the filtering cartridge back into place;
- Close the filter with the relevant end plug;
- Re-open the valve upstream of the filter to open the hydraulic system.

N.B.: When replacing the filtering cartridge, carry out the same operations described above and select the filtering cartridge from those indicated in the "SPARE PARTS" table according to the filtering cartridge used.

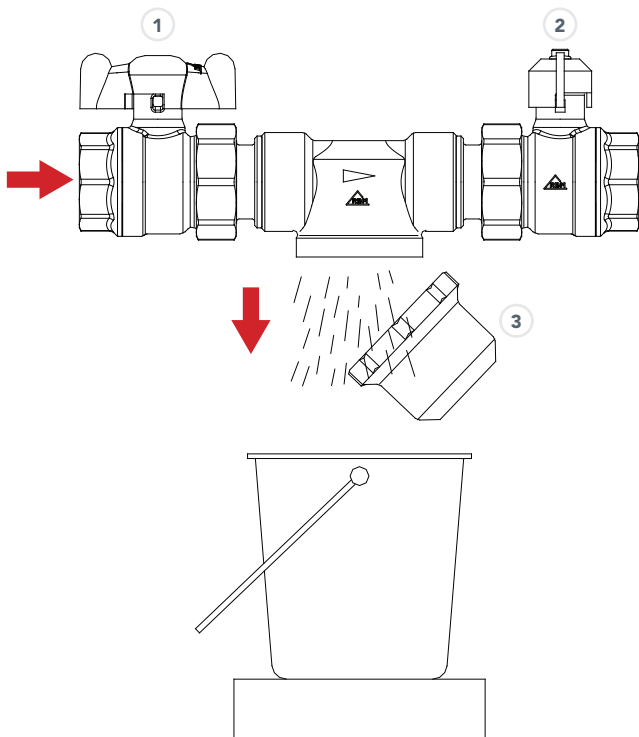

Fig. 1: The above image shows how to perform the line filter maintenance for cleaning/replacing the filtering cartridge.

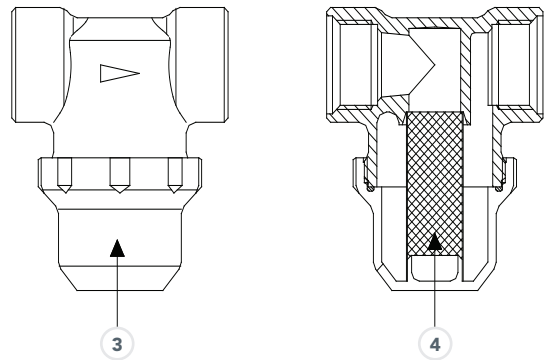
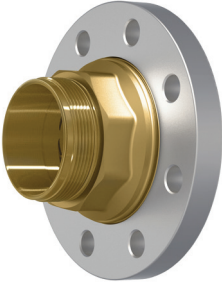



Fig. 2: Below is the line filter with indication of its structural components.

- ① Valve 1
- ② Valve 2
- ③ End plug
- ④ Filtering cartridge

ACCESSORIES

Product	Code	Size	DN	Description
	120.04.00	1/2"	DN 15	THREADED FLANGE PN 16 <ul style="list-style-type: none"> • Nickel-plated brass body; • UNI-EN-ISO 228 M threaded connection; • UNI 2223 PN 16 Flanged connection DIN 2566 PN 16; • P_{max} max. operating pressure: 16 bar; • Max. temperature: 150 °C;
	120.05.00	3/4"	DN 20	
	120.06.00	1"	DN 25	
	120.07.00	1" 1/4	DN 32	
	120.08.00	1" 1/2	DN 40	
	120.09.00	2"	DN 50	
	120.10.00	2" 1/2	DN 65	
	120.11.00	3"	DN 80	
	120.13.00	4"	DN 100	

SPARE PARTS: CARTRIDGE FOR LINE FILTER

Product	Measurement	Filtration rating			
		800 [µm] Code	300 [µm] Code	100 [µm] Code	50 [µm] Code
	3/8"	1041.005	1041.015	1041.055	1041.025
	1/2"	1041.005	1041.015	1041.055	1041.025
	3/4"	929.005	929.015	929.055	929.025
	1"	959.005	959.015	959.055	959.025
	1" 1/4	930.005	930.015	930.055	930.025
	1" 1/2	931.005	931.015	931.055	931.025
	2"	931.005	931.015	931.055	931.025
	2" 1/2	1156.003	1156.013	-	1156.023
	3"	1156.003	1156.013	-	1156.023
	4"	1156.003	1156.013	-	1156.023

SELECTING THE FILTER

The choice of filtering mesh is always at the discretion of the user; as a rule, we indicate:

- 50-100-300-800 micron for drinking water
- 300 micron for well water

FOR FURTHER INFORMATION

The filtering cartridge is the most important element of the filter; it features a cylindrical body with rhomboidal mesh made of AISI 304 stainless steel.

The number of mesh holes per cm^2 is crucial for selecting the filter correctly. A filtering cartridge, in fact, stands out from another depending on the amount of mesh holes present. The narrower the filter mesh holes, the tighter the filter mesh, therefore, the greater the number of mesh holes per cm^2 , the greater the filtering capacity of the filter. It is necessary to know the size of a single filtering mesh hole to understand how many holes are present per cm^2 .

Each filtering cartridge is accompanied by a number expressed in micron [$1\mu = 0.001 \text{ mm}$] that expresses its filtering capacity. This number represents the diameter of the rim [D: see figure] enclosed inside the rhomboidal mesh of the filtering cartridge. The greater the value expressed in micron, the wider the filter mesh holes, resulting in less mesh holes per cm^2 and, therefore, a lower filtering capacity.

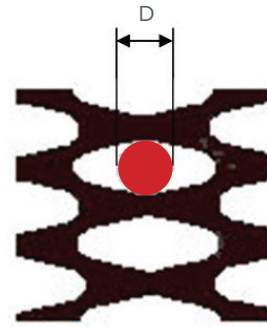

RBM spa reserves the right to improve and change the described products and related technical data at any moment and without prior notice: always refer to the instructions attached with the supplied components; this sheet is an aid, should the instructions be extremely schematic. Our technical office is always at your disposal for any doubt, problem or explanation.