

Company Profile

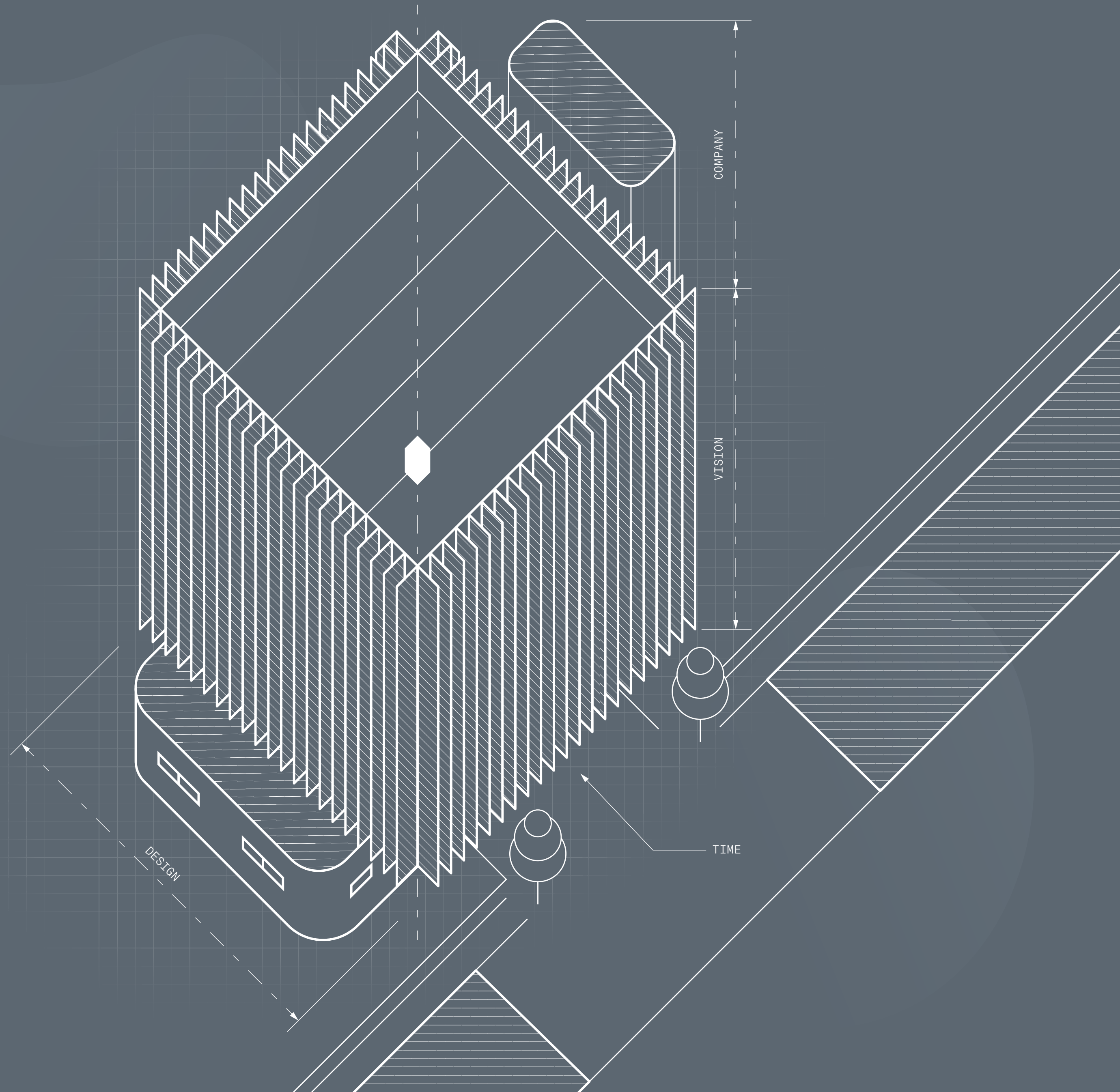



 PLAY
VIDEO

Who we are

Founded in 1953 by the Bossini family in Lumezzane, RBM has become a **leading company in the plumbing and heating industry**, operating worldwide.

The Group is continuously growing and now has:

- 5 production plants in Italy
- 2 secondary offices (France and Belgium)
- 3 commercial branches worldwide (Netherlands, Australia, and China)
- 2 representative offices (Romania, Poland)
- + 300 employees
- + 50 patents
- Experience showrooms
 - Brescia
 - Milano
 - Roma
 - Cortina
 - Genk (Belgio)
 - Aix-en-Provence (Francia)
 - Shanghai (China)
 - ...

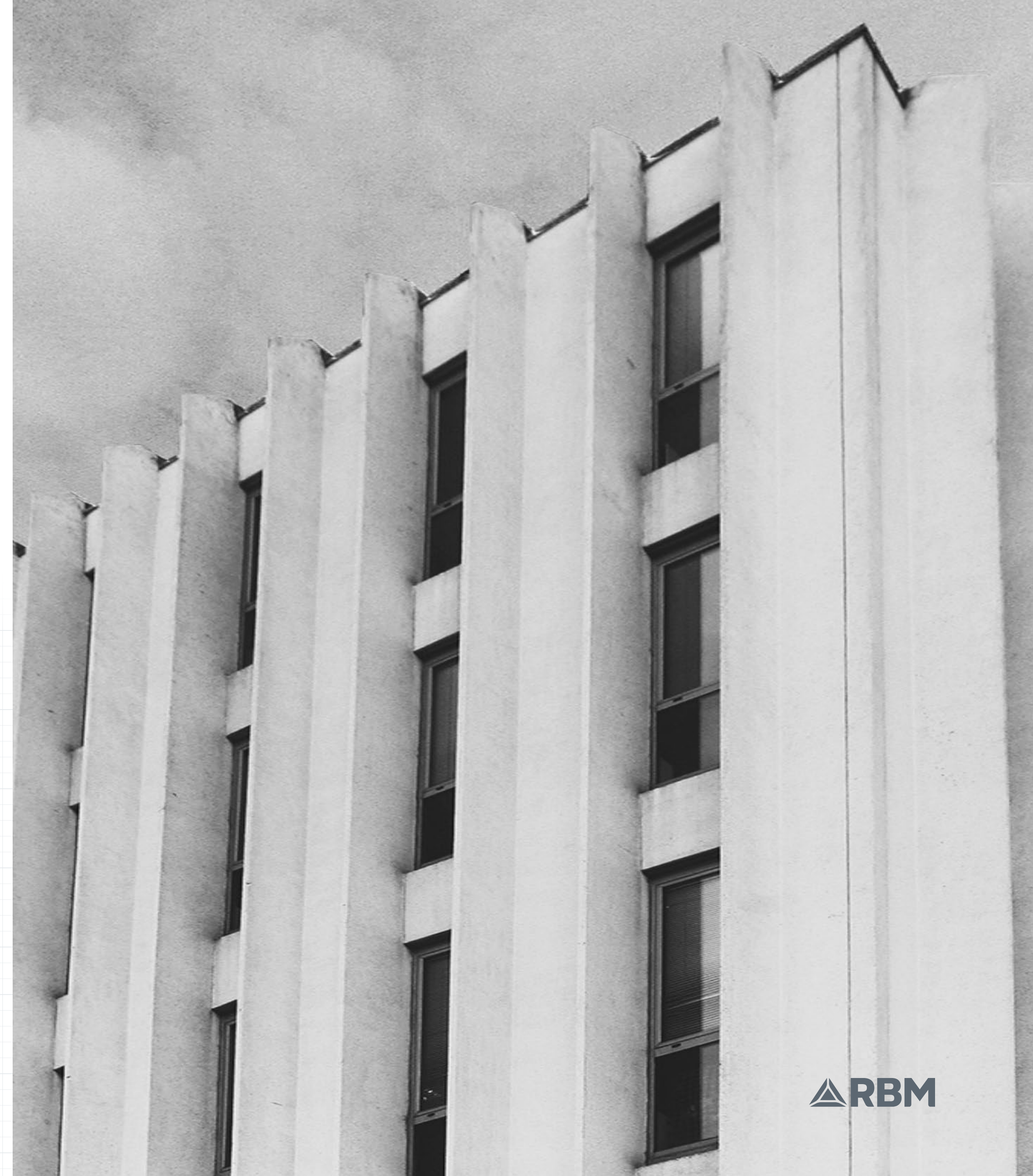

MORE.

wellbeing

 PLAY
VIDEO

Inspiration

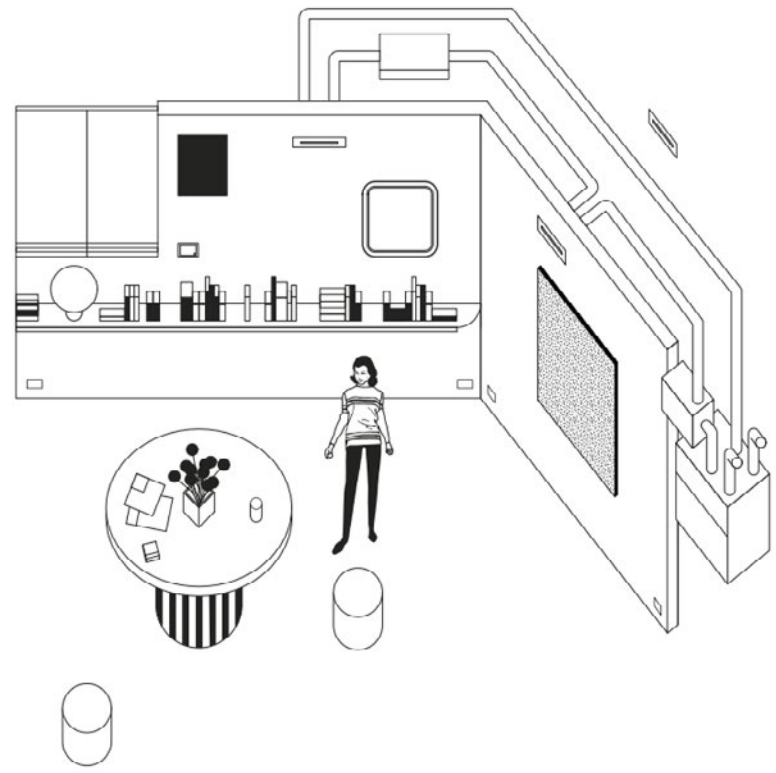

Climatic Wellbeing

Climatic Wellbeing means feeling comfortable in the places where you live and work. It is a complex condition to achieve and we must overcome the notion that only by controlling the temperature we can guarantee it. It is a delicate balance of environmental conditions given by the harmony between quality and air circulation, temperature, humidity, and noise.

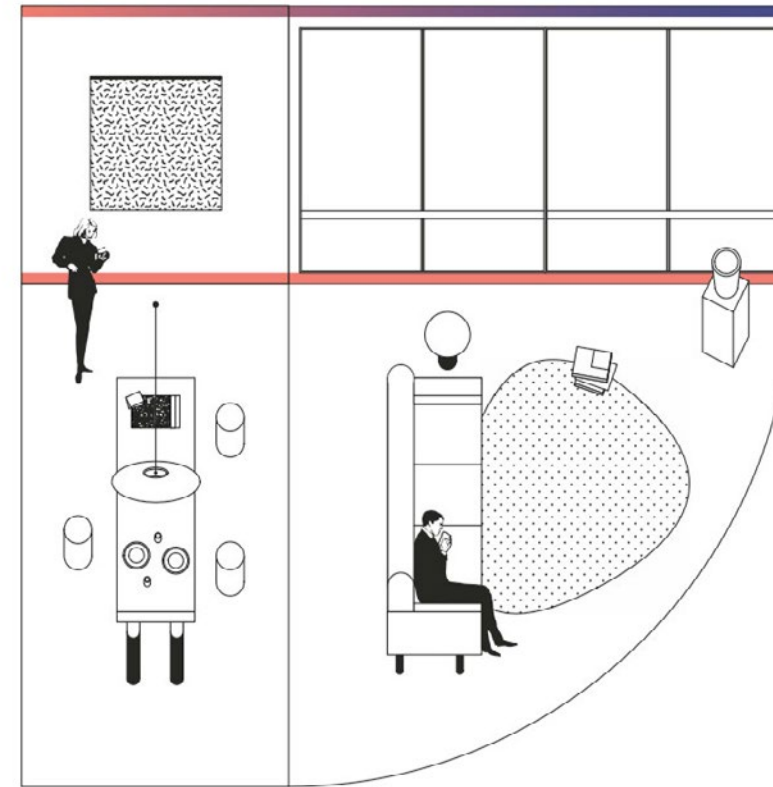

Natural Wellbeing

MORE solutions allow you to control the climate conditions of the spaces, starting from a straightforward concept: imitating nature. Without drafts and minimizing noise, MORE solutions will allow you to manage all the indicators of wellbeing that determine the wellbeing within an environment. Customized solutions, architecturally integrable and efficient, in which man is at the center.

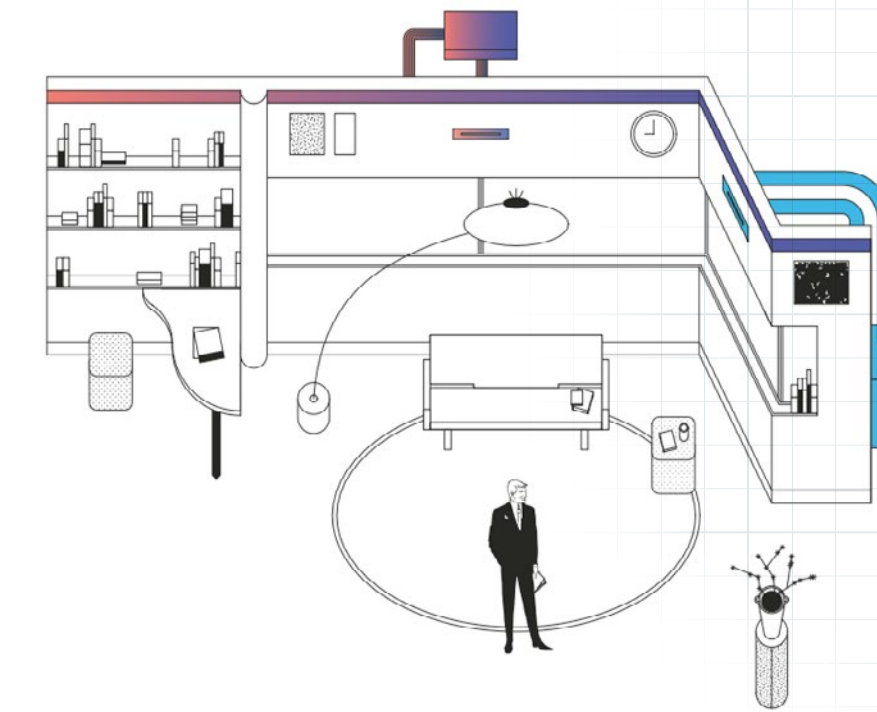

Focus on the person

Even if designed and inhabited by the same person, two houses can never be identical. MORE solutions adapt to people's habits and needs; they adapt to external circumstances and the different uses of the spaces in which they live and work. MORE systems and technologies adapt to man, improving people's quality of life.

Showroom

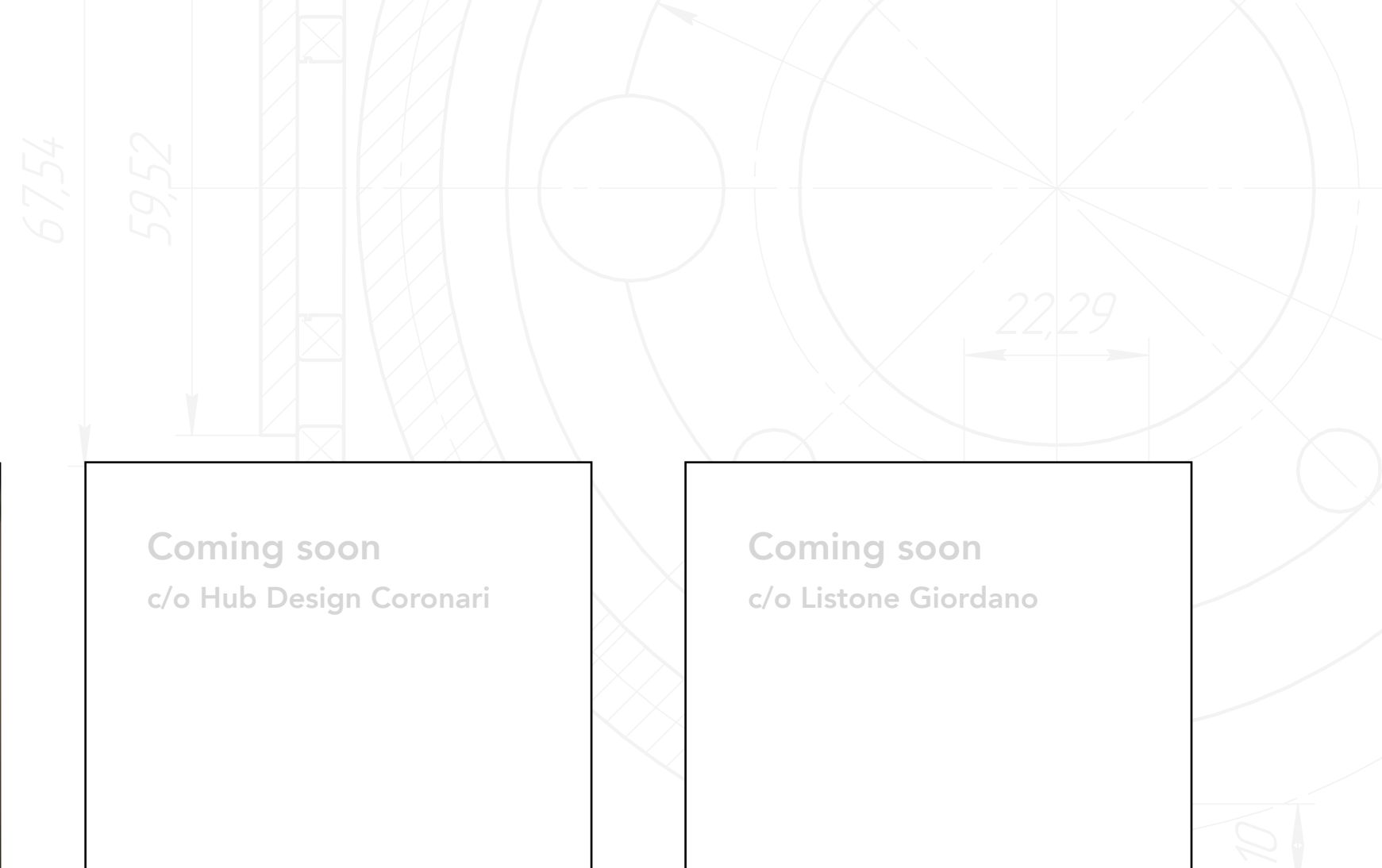
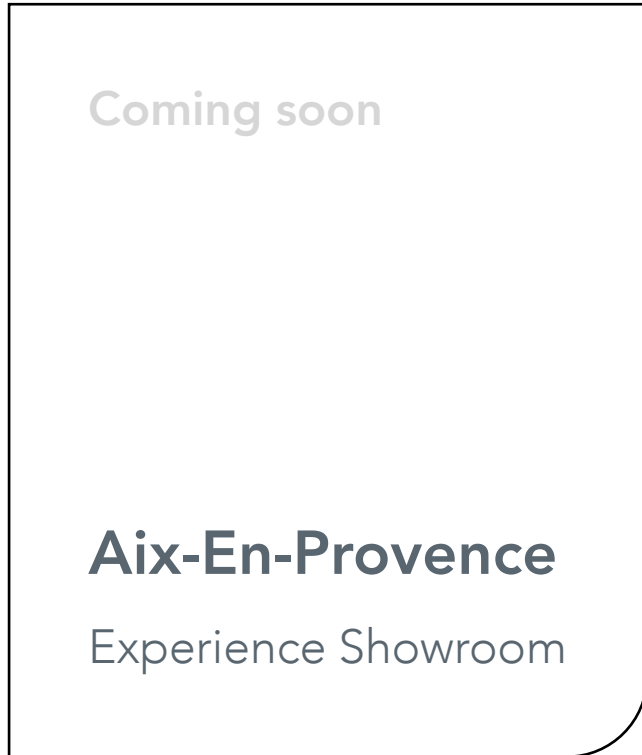
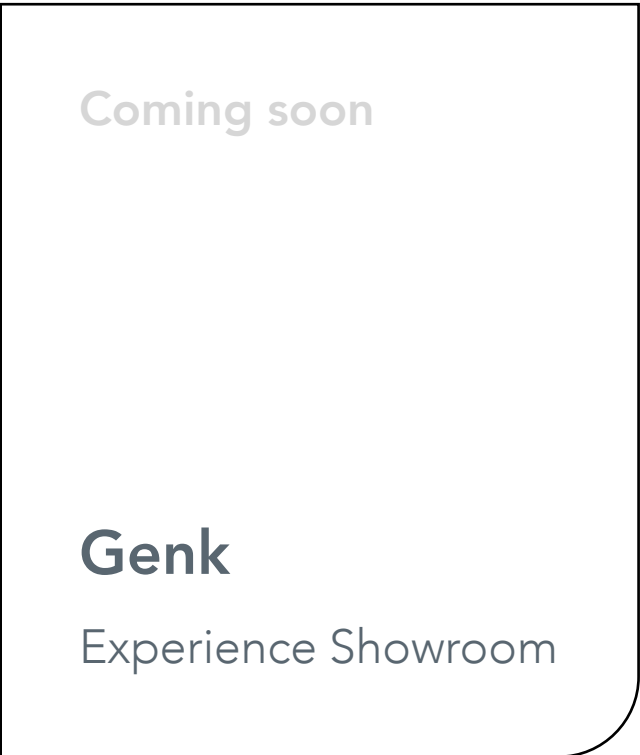
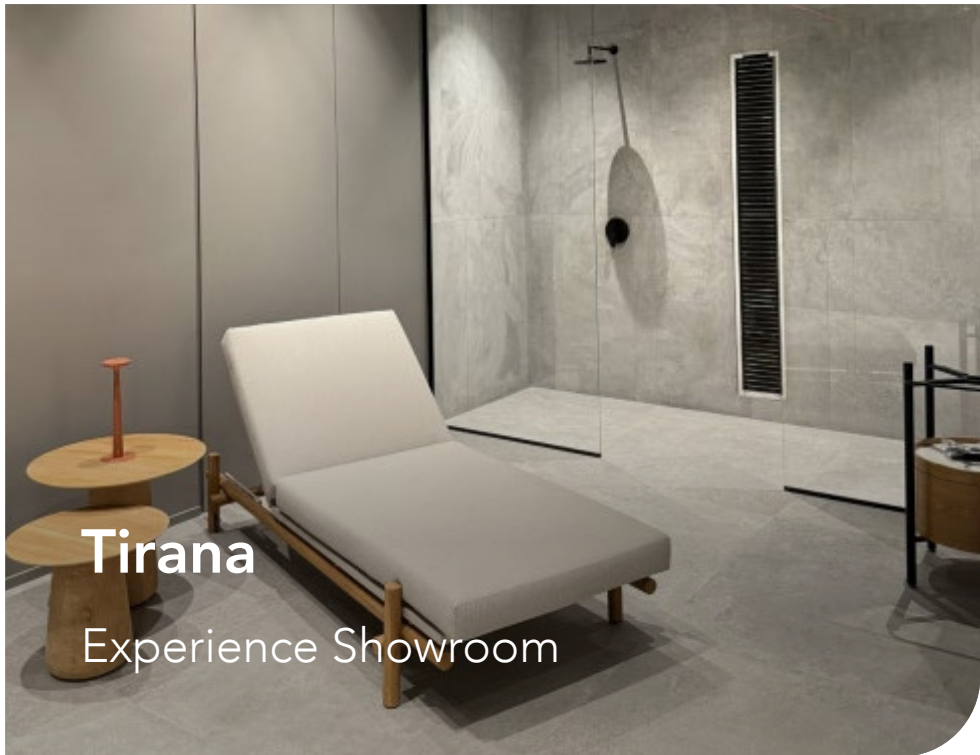
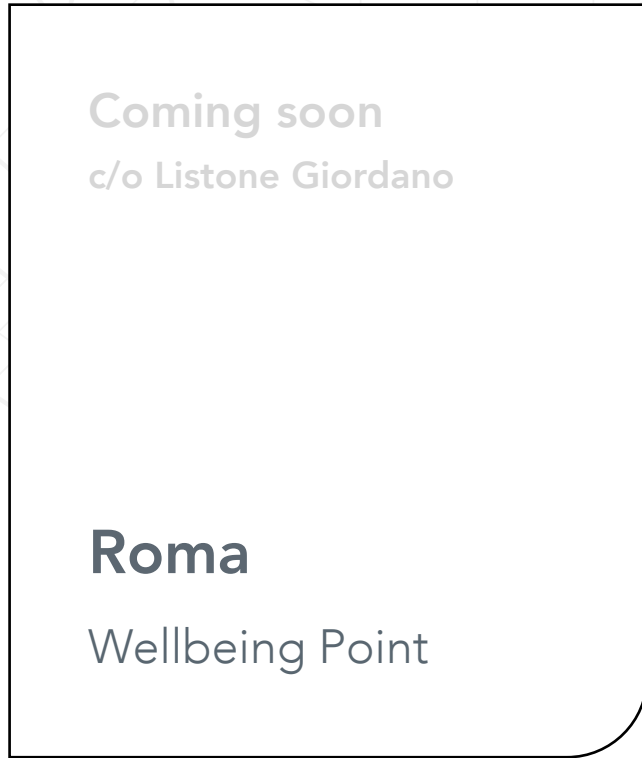
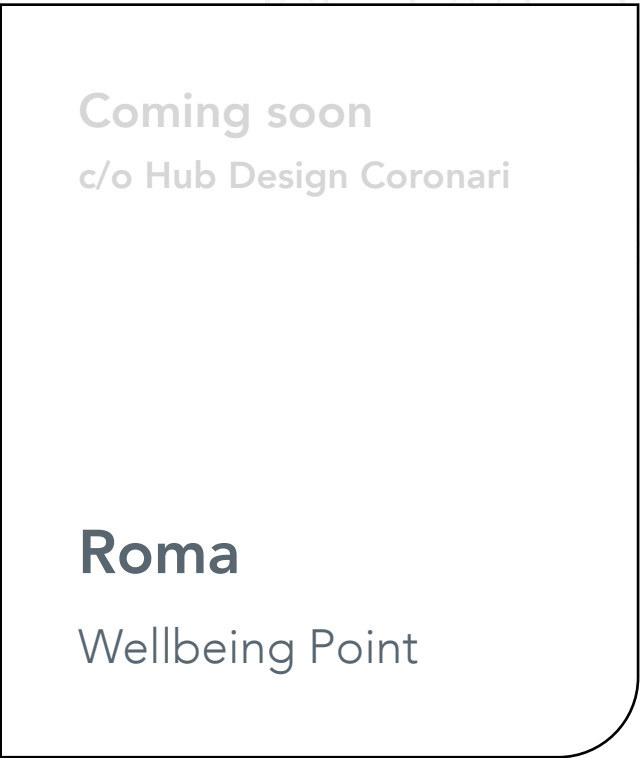
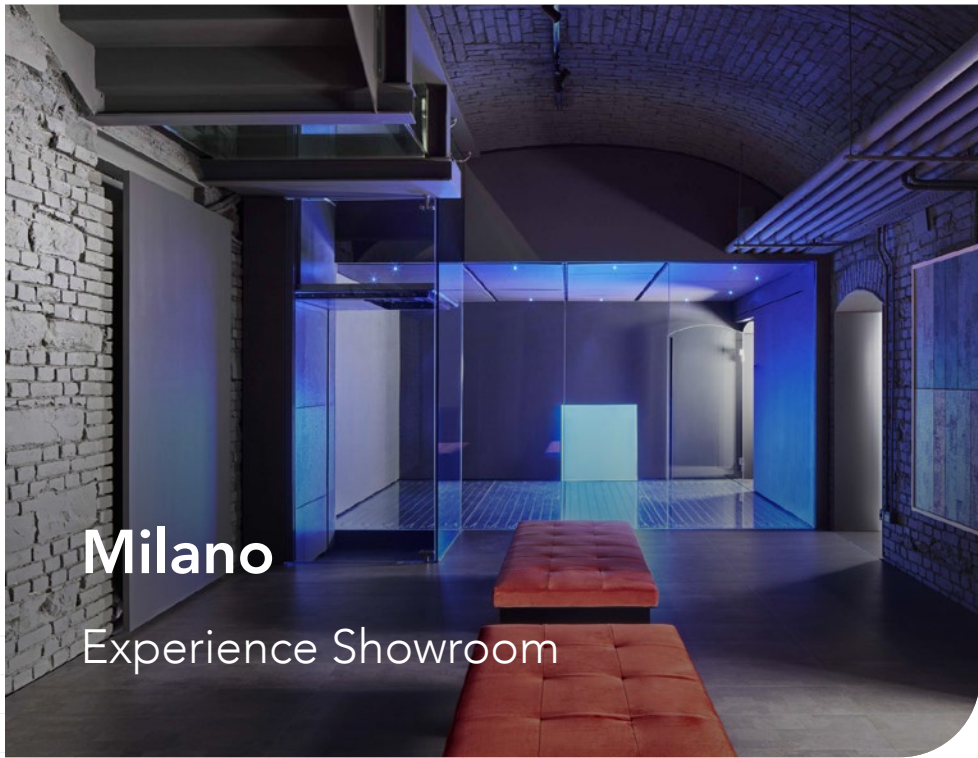

Our history



1953

RBM is founded in Lumezzane by the Bossini family.

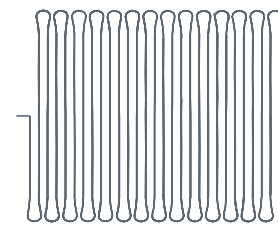

1999

The RBM KILMA division is born.

2000

Acquisition of **Sipla spa** (now Sipla Stampaggio srl), a company involved in the molding of plastics for third parties in the following sectors: electrical, plumbing, and mechanical, medical, gas and automotive.

2004

The RBM METIS division is born.

2007

The line for the production of **PE pipes** is set up

2018

The line for the production of **HIUs** (Heat Interface Unit), **substations of heat** used in **district heating**.



2021

The showroom is inaugurated in **Milan in the Brera area**.

The new division **MORE – the Wellbeing**, to offer integrated systems that adapt to the habits, the needs and requirements of people, improving their quality of life: everything is connected, controllable and integrated, minimizing the time it takes to adapt of environmental conditions to new needs or changed external conditions.



2025

Acquisition of **Nexeta**.

1983

RBM expands and moves to S. Giovanni di Polaveno.



1999

RBM Benelux is founded.

2002

RBM France is founded.

2010

The brand name is taken over GS Gnutti Sebastiano. **RBM SFERIKA** is born, which deals with the production and marketing of ball valves.



2019

RBM IBOX is created and **R&D Lab**, with ample space designated for reception, showroom and laboratory.

2006

The following is set up the plant for the production of **insulating panels for radiant systems**.

2024

Publication of the **first sustainability report**.

Logo evolution

1956

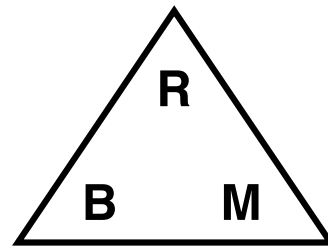

1988



2009



2020



2018



2021

Launch of
MORE▲
wellbeing



Polaveno headquarters

Surface: **17,000 m²**.

- Mechanical workshop.
- Moulding and shearing of brass components.
- Production of polystyrene insulating panels.

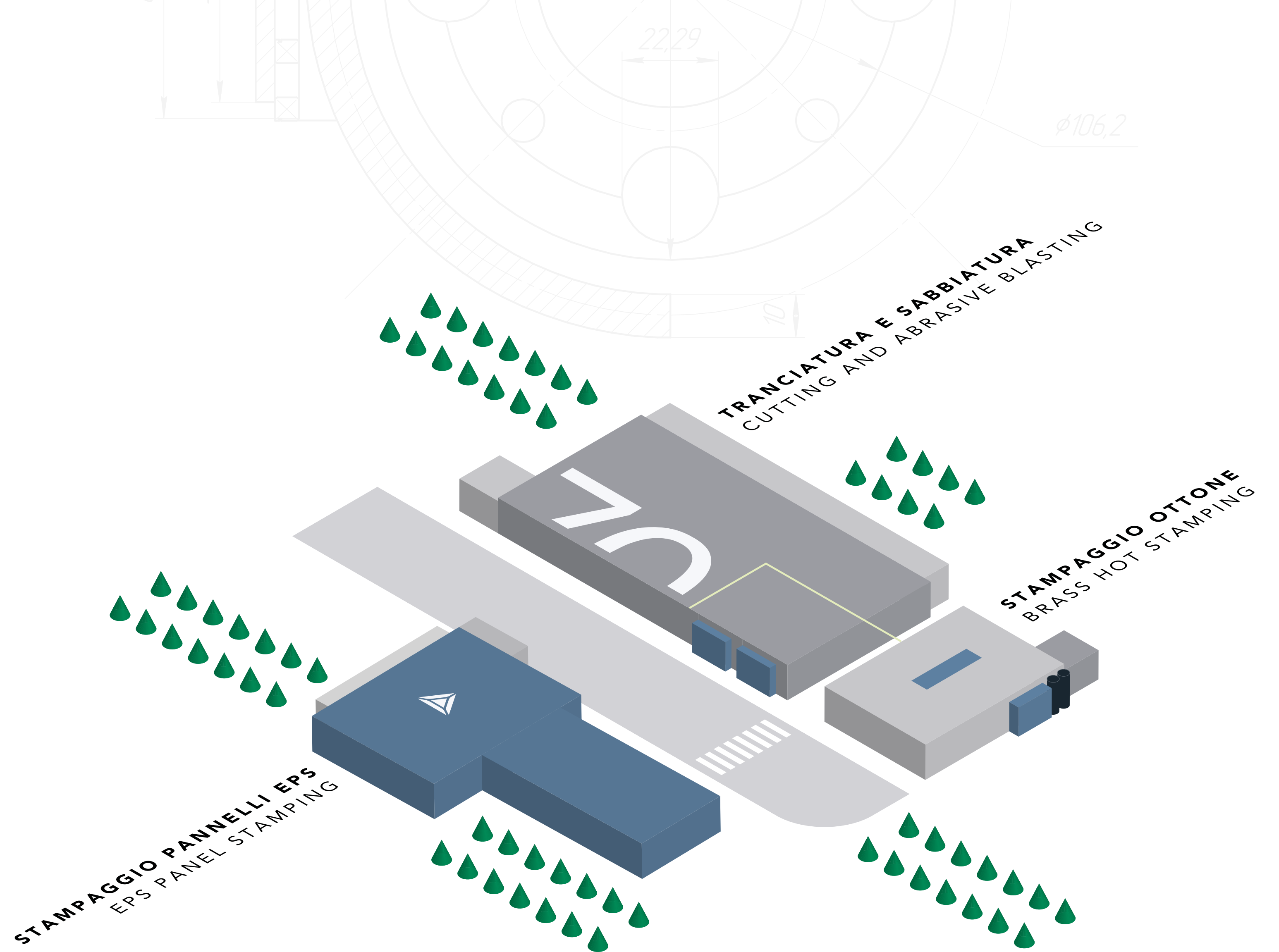

Nave headquarters

Surface: **55,000 m²**.

- Machining, finishing and assembly.
- Incoming and outgoing goods warehouse.
- Pipe decoiling.
- Pipe extrusion.
- Showroom and R&D Lab.

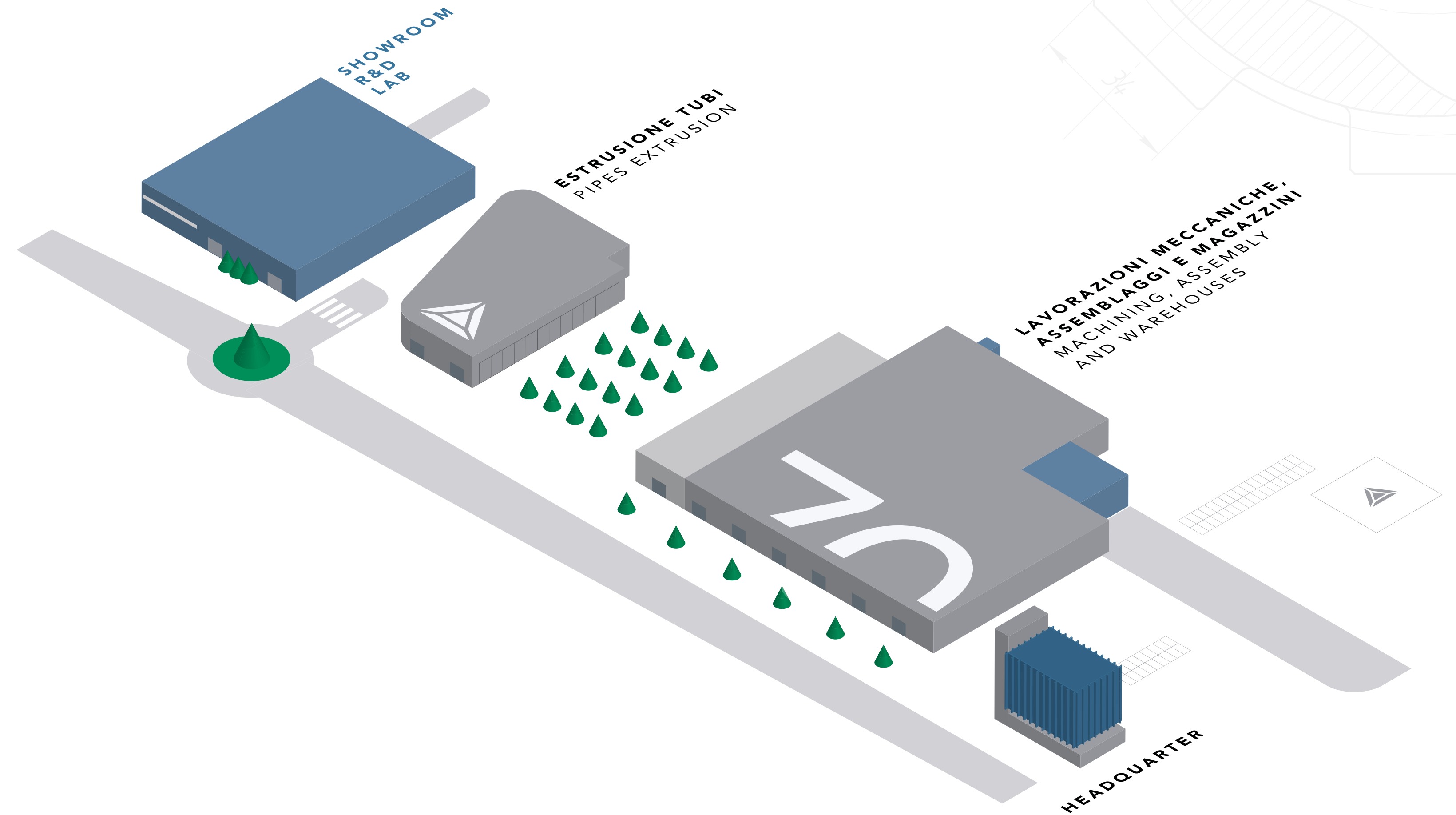

Villanuova sul Clisi headquarter

Surface area: **3,500 m²**.

- Plastic moulding.

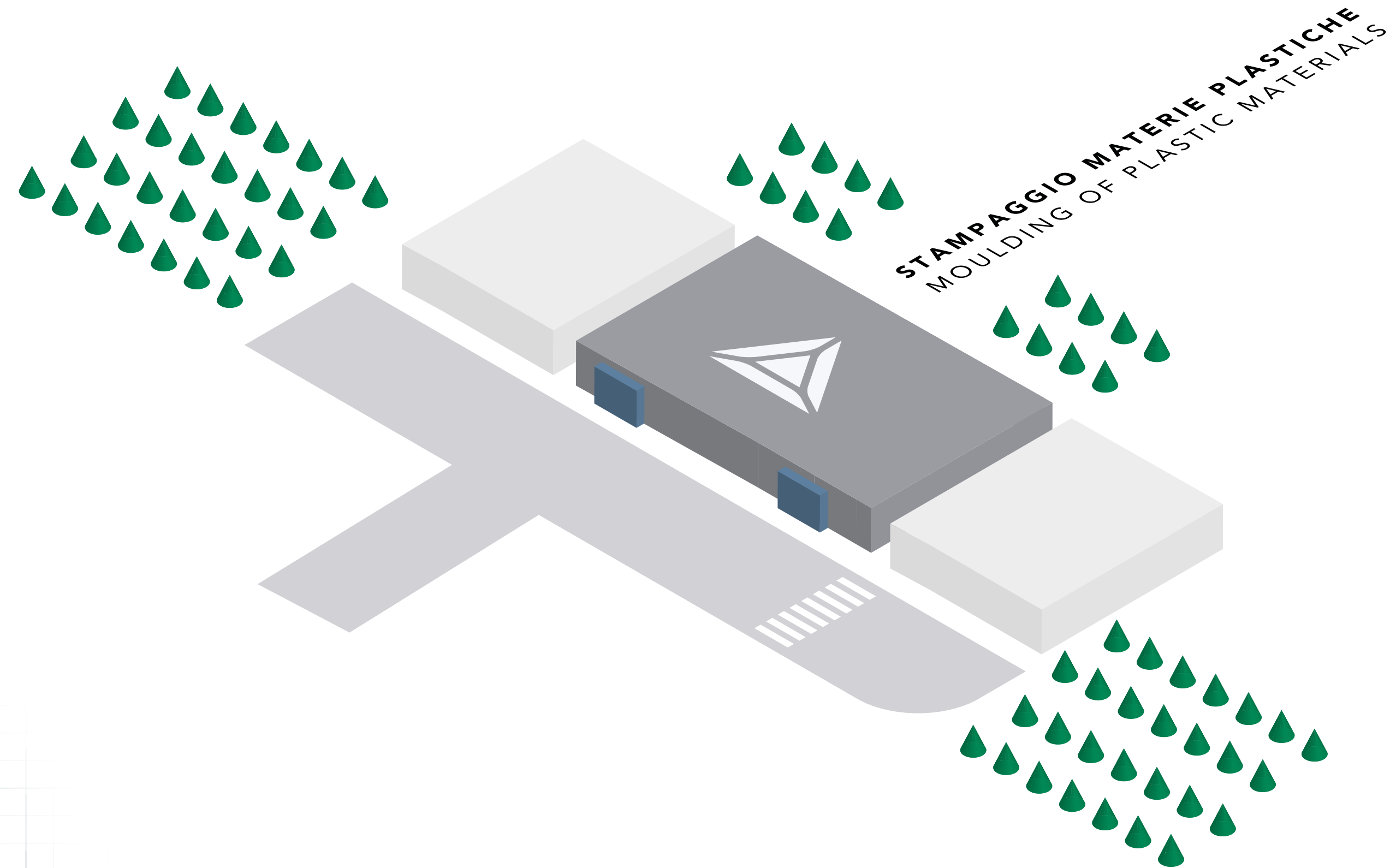

A complete product range

RBM designs and manufactures innovative plumbing and heating components and systems, characterised by efficacy and efficiency, oriented towards energy saving, easy to install and simple to use, without ever sacrificing quality.

RBM **anticipates technological advancements** by placing them at the service of always new ideas and projects, aimed at **maximum efficacy and efficiency, from individual components to complete climate comfort systems**. These are innovations that often work unseen and silently, helping to **simplify the quality of life of those who use them** through a constant focus on easy assembly and use, optimising living comfort with respect to individual needs.

Technological innovation at the service of increasing efficacy and efficiency

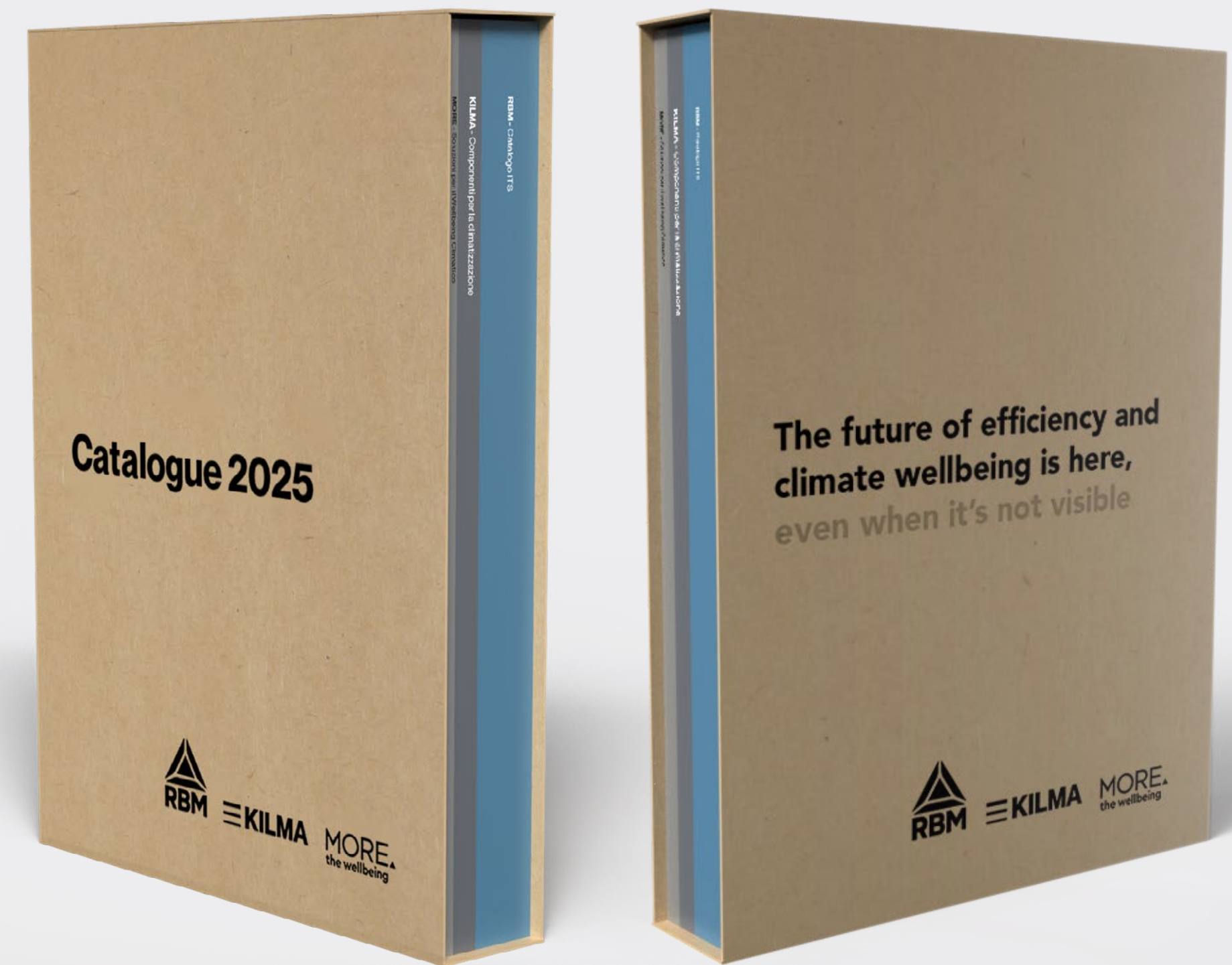



Catalogue ITS

Hydrothermal distribution

Hydrothermal distribution

The **distribution system** is that portion of the **plumbing systems** that **receives the service and/or thermal energy from the production system and conveys it to the emission system** responsible for climatic comfort. This division houses all those products that allow the separation between the various subsystems, the connection and joining of products, the relaying to the users, the distribution of energy and the interfacing between centralised systems and thermally autonomous consumers.

Hydrothermal distribution

Catalogue ITS

Boiler room distribution

- Hydraulic separators
- Multimix booster units DN25
- Multimix booster units DN32
- Accessories for multimix booster units



Zone valves

- Zone valves
- Actuators for zone valves
- Compact zone valves
- Actuators for compact zone valves



User modules

- Modular hydraulic unit
- MZ2 modular zone module
- MZ modular zone modules
- Accessories for modular zone modules
- User modules RBM Hub

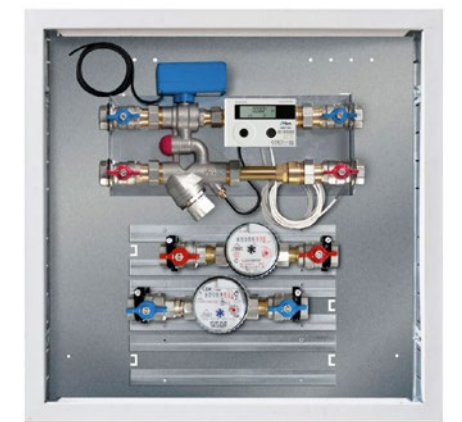

Utility satellites

- Utility satellites



Direct metering

- Single-block heat meters
- Split heat meters
- Water meters
- Monitoring and remote reading systems
- Accessories



Installations upgrade kit

- Installations upgrade kit
- Heating cost allocators
- Monitoring and remote reading systems
- Radiator replacement kit



Hydrothermal distribution

Catalogue ITS

Radiator and fan coil distribution

- Manifolds for heating and cooling systems
- Manifolds for large flow rates
- Accessories for manifolds
- Plastic housing boxes



DHW distribution

- Manifolds for DHW systems
- Plastic housing boxes
- Thermostatic mixers



Pressure reduction

- Diaphragm pressure reducing valves
- Piston-operated pressure reducing valves
- Water hammer arrestor



Control and safety components

- Safety relief valves
- Bypass valve
- Filling units



Ball valves, check valves and shut-off devices

- Ball valves
- Check valves
- Accessories



Fittings

- Fittings for valves and piping
- Fittings for manifolds



Hydrothermal distribution

Catalogue ITS

Multi-layer pipes

- Pe-xc plain multi-layer pipe
- Pe-xc multi-layer thermally coated pipe
- Pe-xc multi-layer pipe with anti-condensation coating
- Pe-rt plain multi-layer pipe
- Pe-rt multi-layer thermally coated pipe
- Pe-rt multi-layer pipe with anti-condensation coating
- Pe-xc multi-layer pipe for gas distribution



Fittings for multi-layer pipes

- Press fittings for multi-layer pipes
- Shut-off taps
- Compression fittings for multi-layer pipes
- Press fittings for multi-layer gas system



Equipment and tools

- Equipment for compression valves and fittings
- Equipment for multi-layer system



Catalogue ITS

Hydrothermal distribution

Energy efficiency

The **energy efficiency** of the plant engineering system is the ability of the system to deliver the same service with **less energy consumption**. This capability is achieved by controlling everything in the best possible manner **to reduce energy losses** while achieving the same final comfort. Also important is the **correct** and **continuous maintenance** of the 'health condition' of the entire plant over time. For these purposes, this division includes **all products for controlling and regulating process** variables such as flow, temperature, humidity and pressure, as well as products required for maintaining plant health.

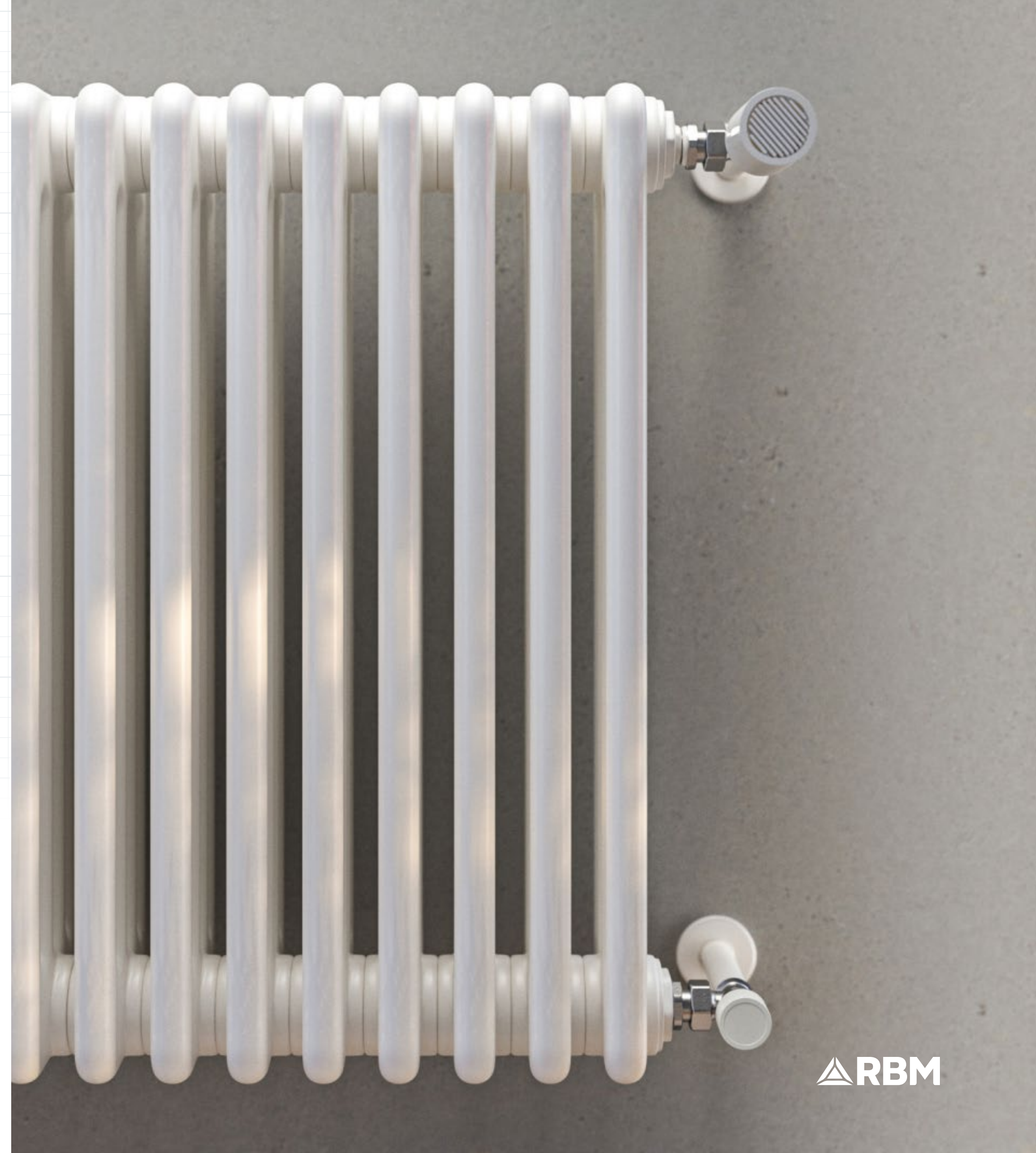

Energy efficiency

Catalogue ITS

Physical treatment

- Cartridge filters
- Air vent valves
- Deaerators
- Sludge remover filters
- Sludge remover/deaerator filters



Chemical treatment

- Condensation neutraliser filter
- Domestic polyphosphate dosers
- Liquid chemical conditioners for air conditioning circuits
- Solid chemical conditioners for heating and cooling system
- Dispensers for solid chemicals



Magnetic treatment

- Compact magnetic sludge remover filters for boilers
- Magnetic sludge remover filters for heat pumps
- "Essential items" kits
- Magnetic sludge remover filters
- Magnetic sludge remover/deaerator filters
- Magnetic sludge remover filters for boiler rooms
- Magnetic anti-scale device
- Magnetic dirt separator filter kits with liquid chemical conditioners
- Magnetic dirt separator filters for RBM Caps



Radiator valves and lockshields

- Thermostatic controls
- Thermostatic controls
- Valves with thermostatic option
- Picv valves with thermostatic option
- Accessories
- Manual valves
- Lockshield regulating valves



Hydraulic balancing

- Balancing lockshield valves
- Flow-rate measuring stub pipe
- Flow control valves
- Picv independent pressure adjustment valves
- Tools and accessories





Catalogue Kilma

Climate comfort

Climate comfort

Climatic comfort can be defined as the feeling of physical and mental wellbeing; a condition of satisfaction with one's surroundings in which we do not feel neither hot nor cold.

In this division, RBM presents **products and systems that contribute to climatic comfort with various radiant heating and cooling systems and accessory equipment for climate and air quality control, regulation and correction.**

Air treatment

Modern homes, built according to energy efficiency standards and advanced insulation, require **controlled mechanical ventilation (CMV)** systems to ensure **proper air exchange**, prevent condensation, and maintain **high indoor air quality**. RBM, through its Air Treatment division, offers a complete range of **solutions for residential and commercial ventilation.**

Climate comfort

Catalogue Kilma

Collectors

- Brass compact manifold kits
- Polymer compact manifold kits
- 1"1/4 Manifold kit
- Manifold kits for industrial application
- Anticondensation manifold kits
- Modular brass manifold kit



Mixing and distribution units

- Mixing and distribution units
- Kilma basic 2 mixing unit
- Kilma easy 2 mixing unit

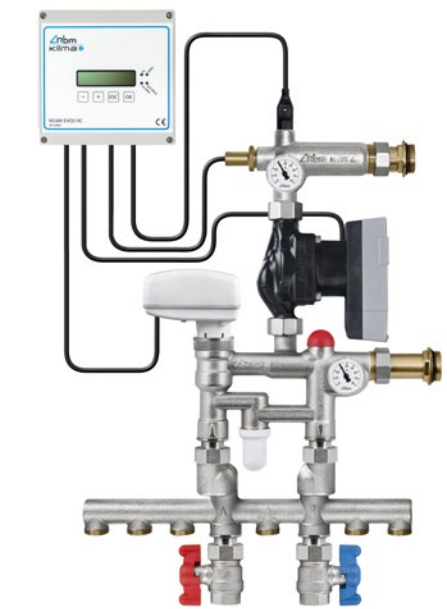

Manifold cabinet

- Manifold cabinet



Insulation panels

- Insulation panels

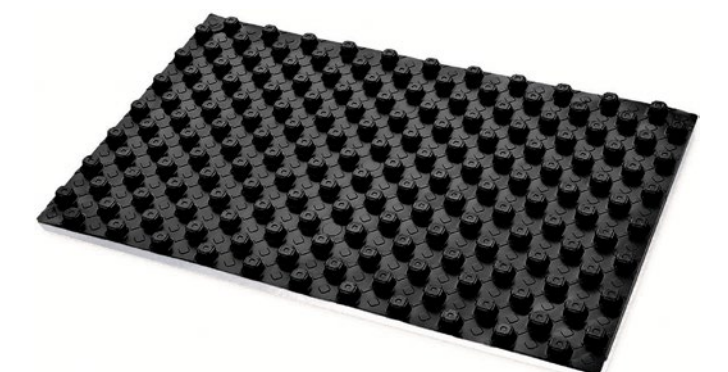

Climate comfort

Catalogue Kilma

Dry insulating panel

- Kilma Futura

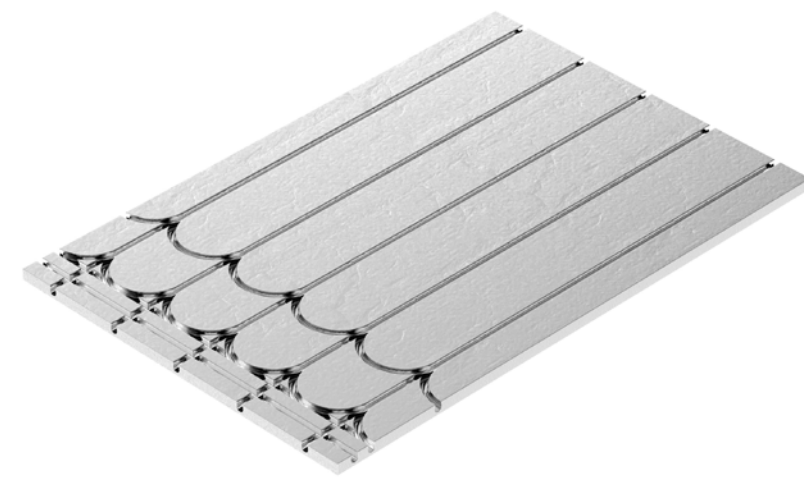

Pipes

- Polyethylene pipes



Accessories for radiant systems

- Accessories for radiant systems
- Distribution accessories
- Equipment for radiant systems



Termoregulation

- Thermostats, programmable thermostats and room humidity regulator



Air treatment

Catalogue Kilma

Air treatment

- Dehumidifiers
- VMC
- Distribution and air terminals

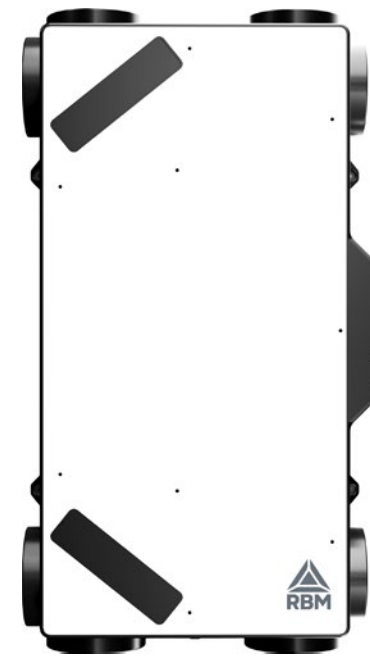

Our Vision

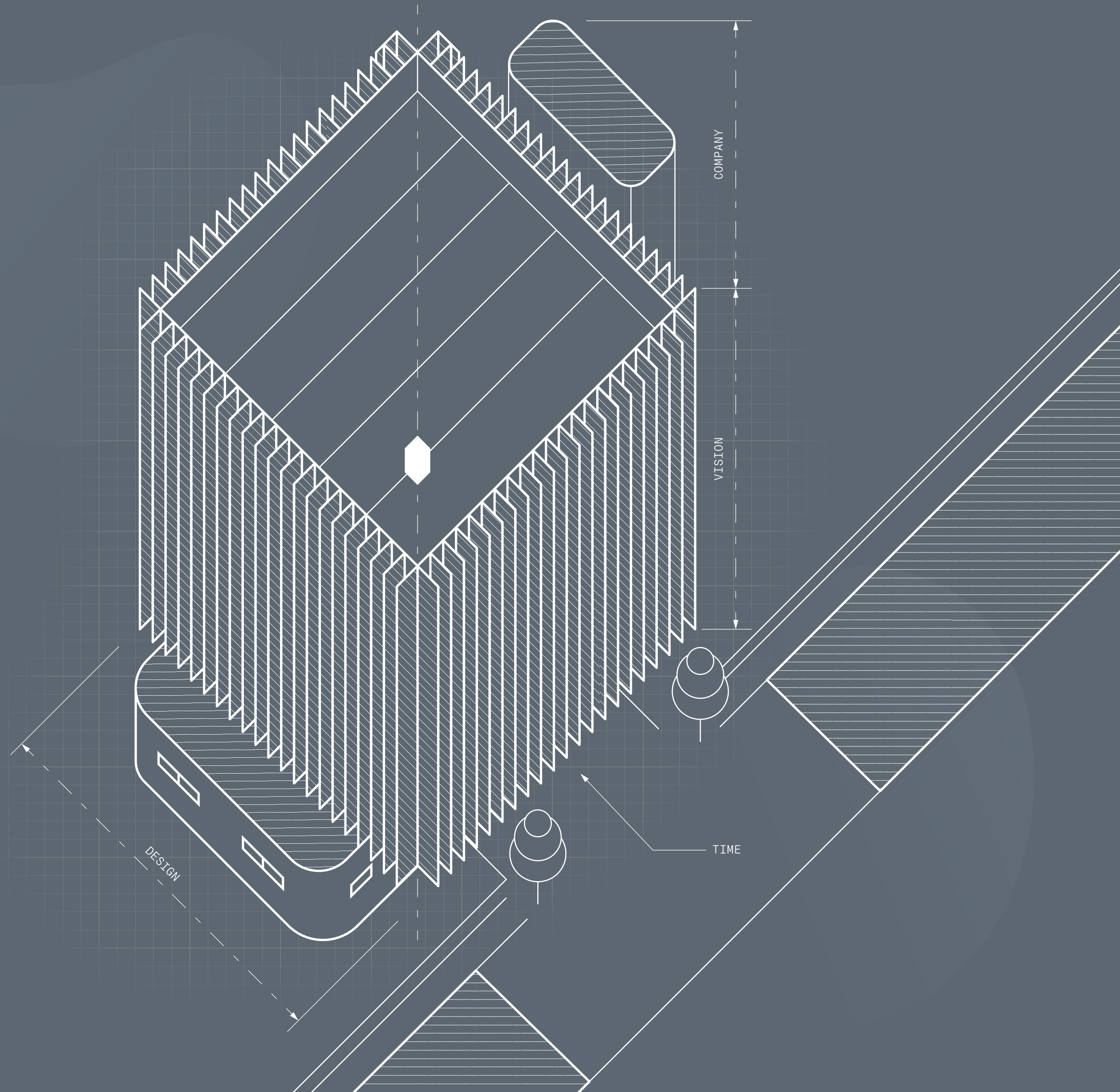

Company

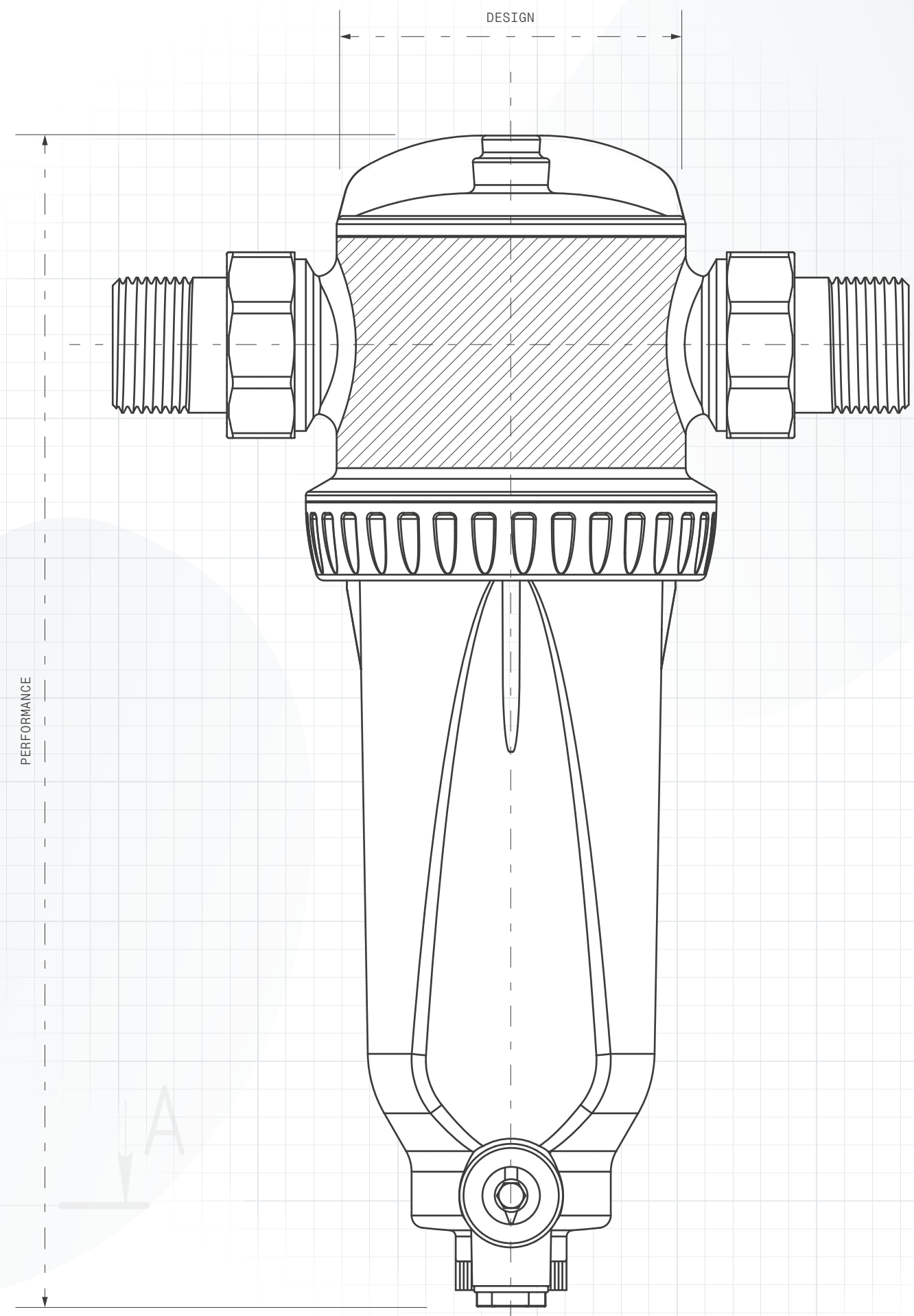

RBM designs and manufactures **highly innovative** components, hydro-thermo sanitary systems and climate wellness solutions, distinguished by their **highly efficient performance and recognised effectiveness.**

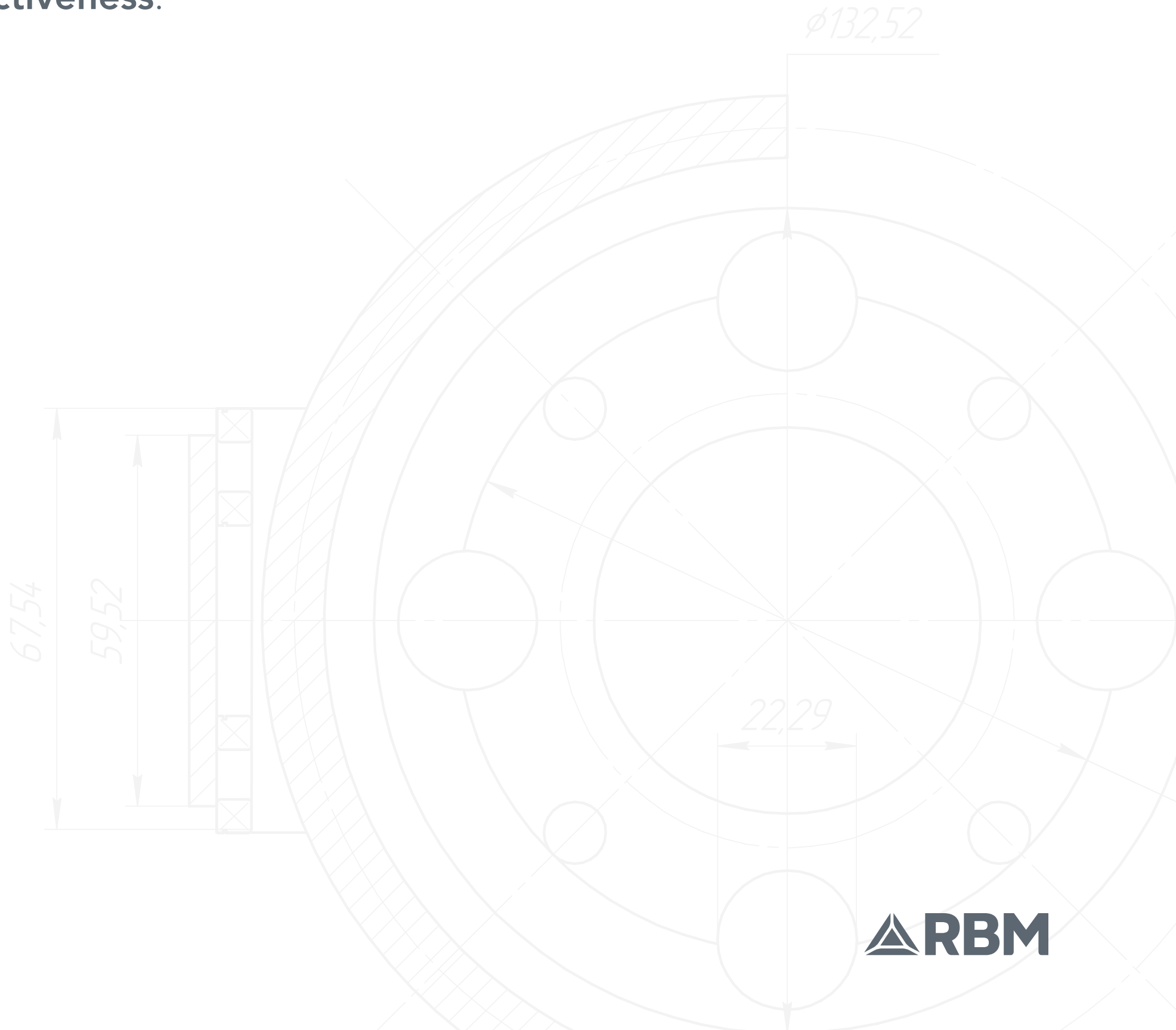

Solutions

We have always focused on solutions that operate invisibly and silently, helping to **simplify and improve quality of life**, with an emphasis on features guaranteeing maximum **ease of installation and use**.

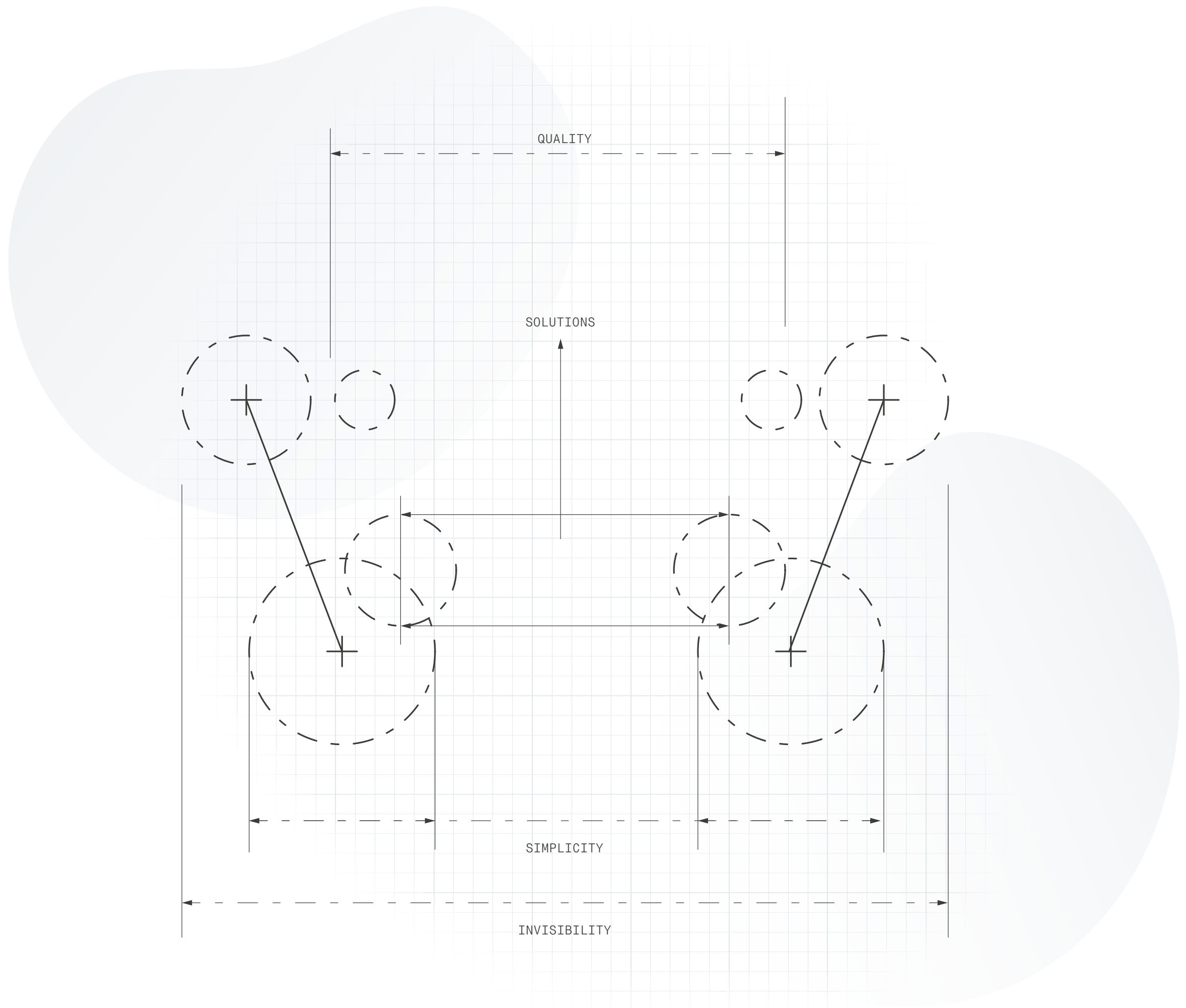

CSR policy

We are convinced that spreading the **culture of climate welfare** and working concretely to make it possible for every individual we will be able to **CREATE A FUTURE** in which cutting-edge technology and sustainability support each other, increasing the mutual value and shared benefits.

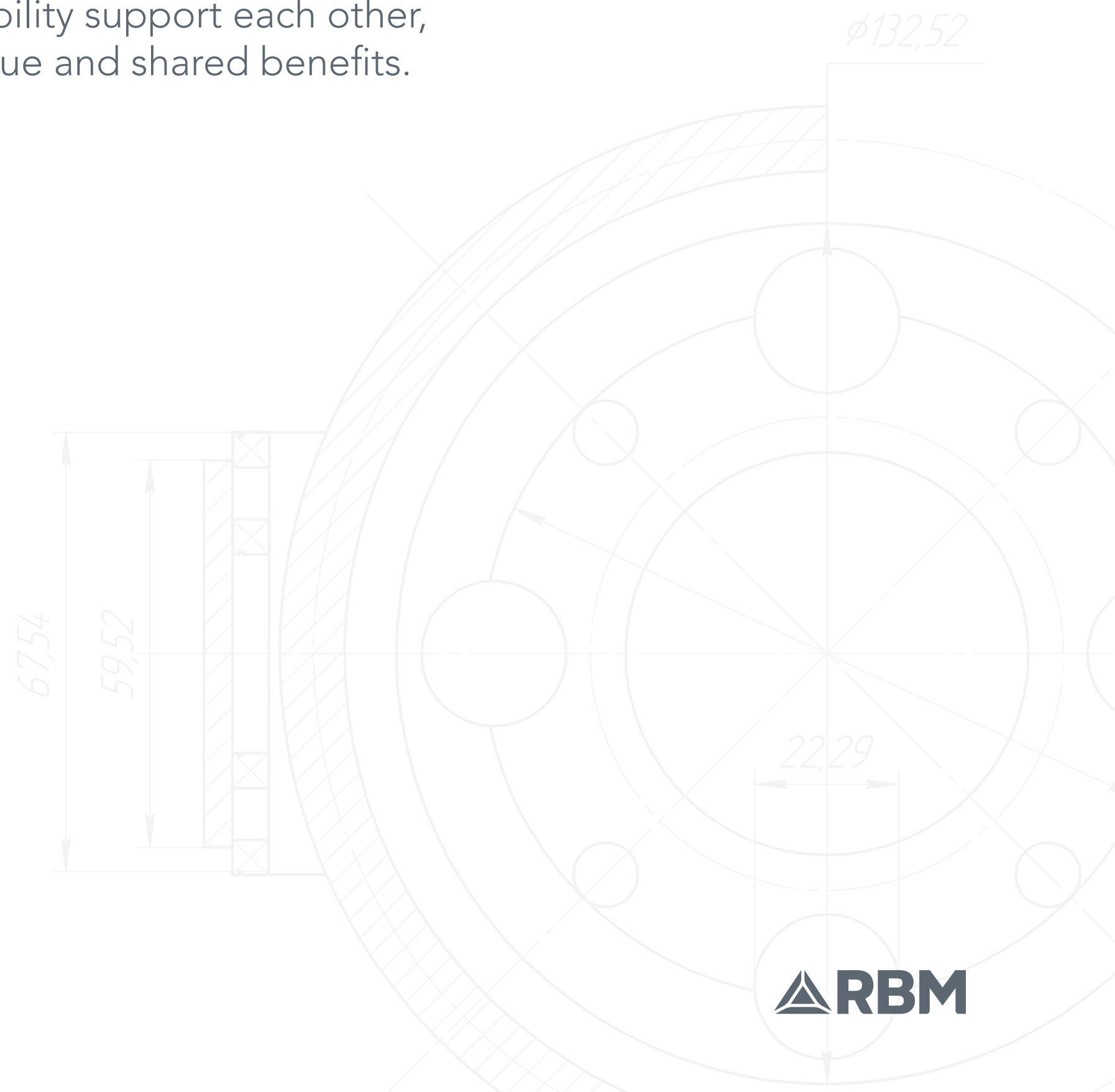
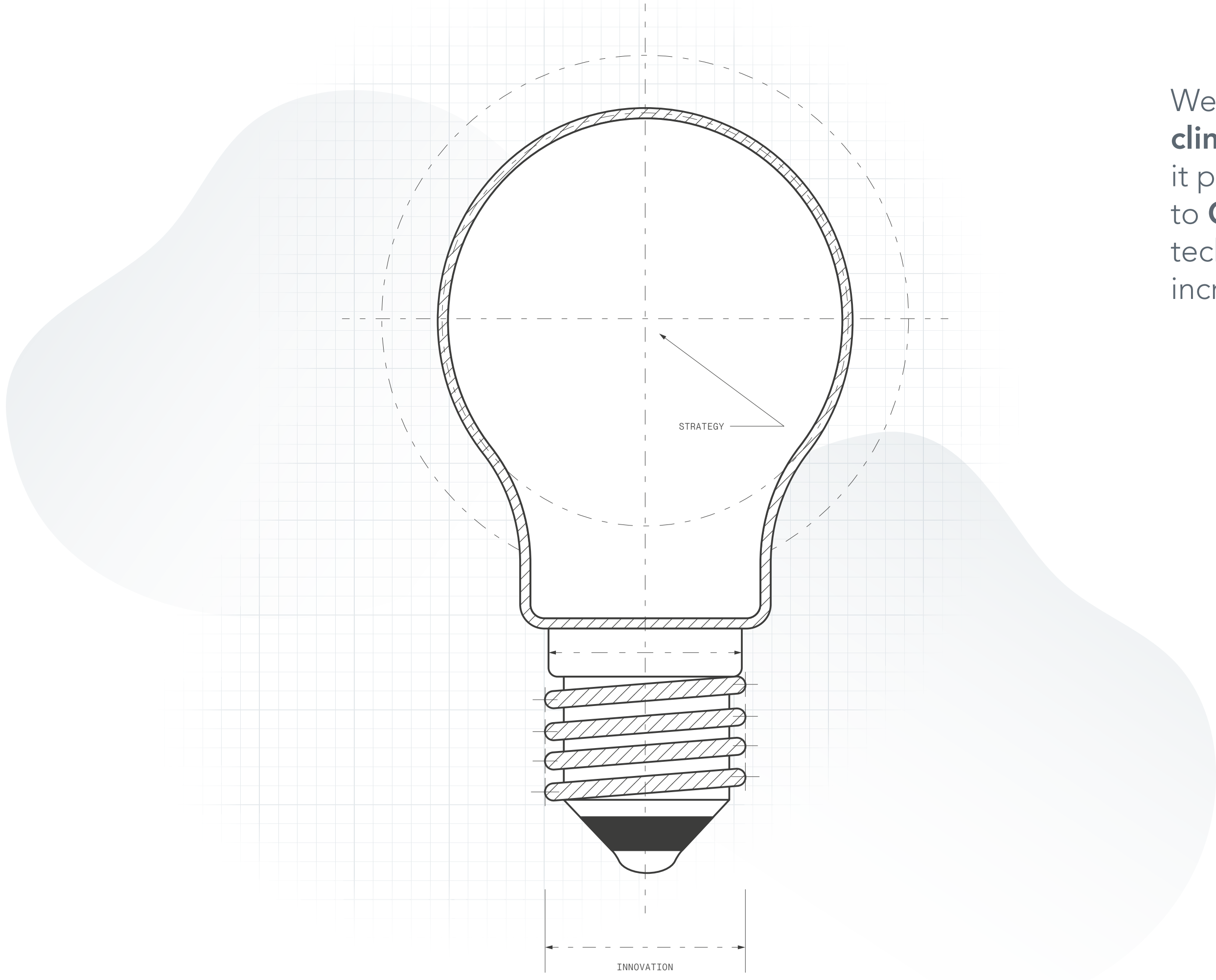

CSR policy

We want to guarantee a governance marked by integrity, transparency and respect, in order to disseminate good business practices and inspire new sustainability standards.

That's why we have defined our CSR vision with a **5-pillar** strategy.

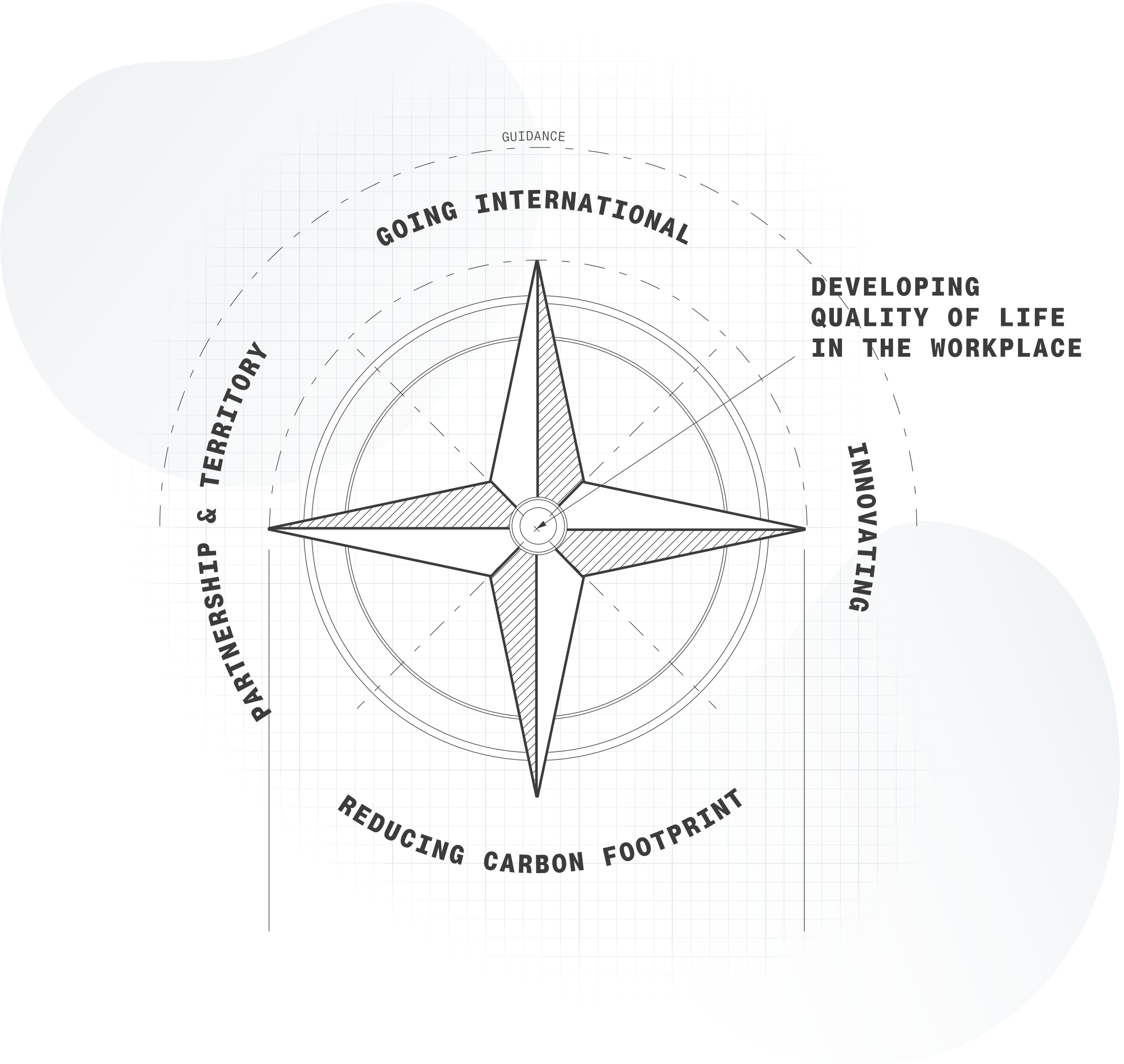
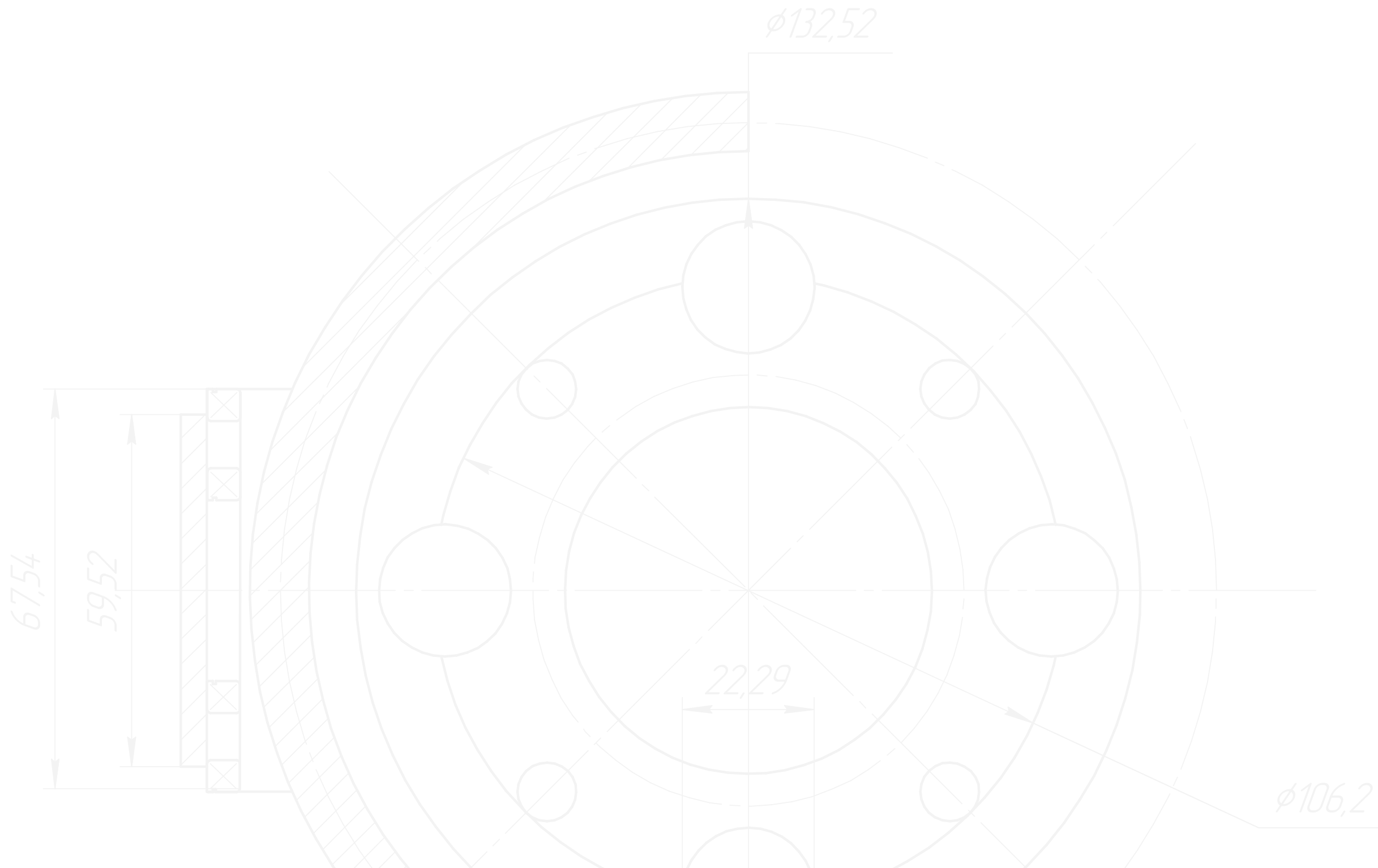

1. Going international

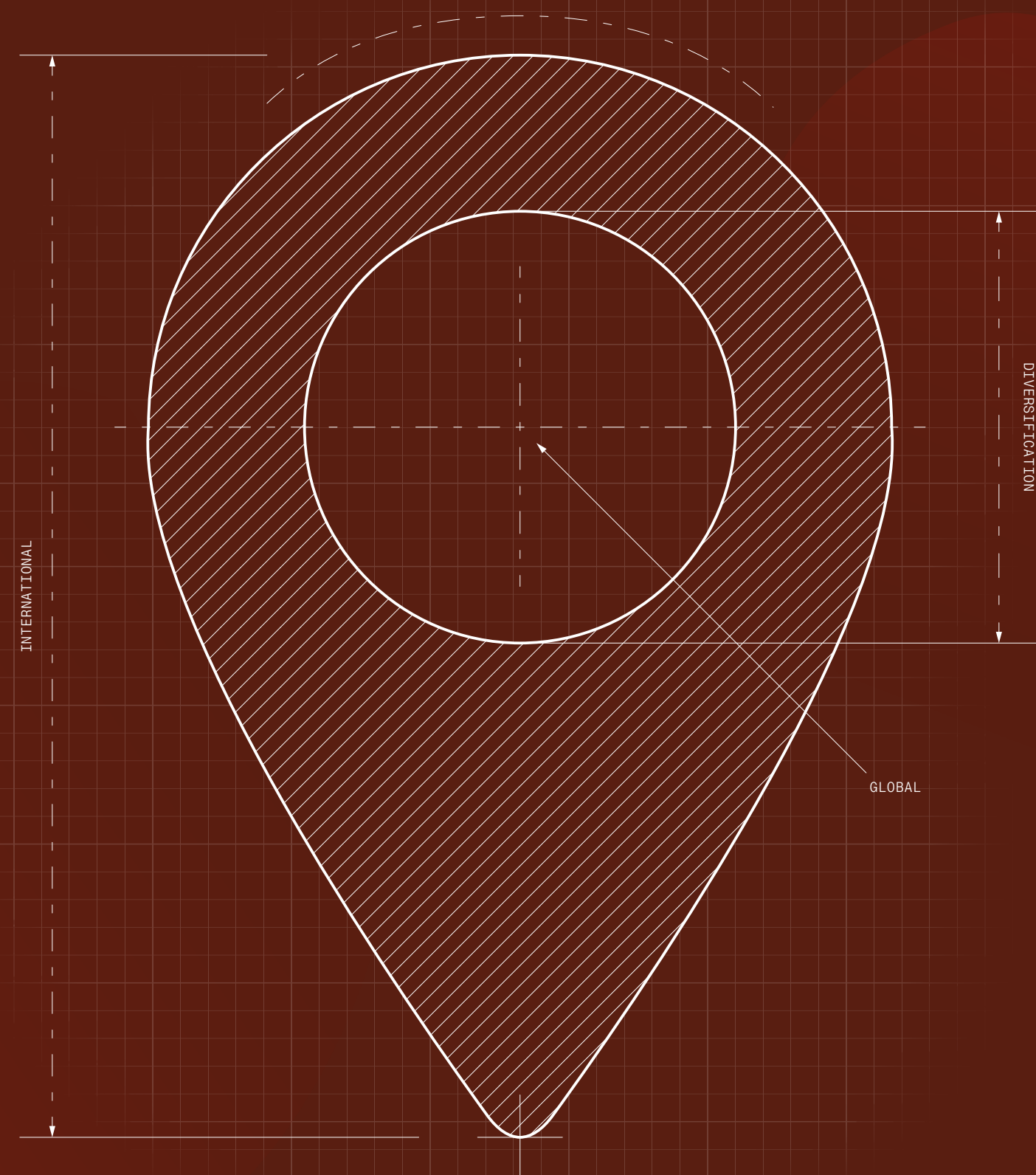

Opening up to international markets, both upstream and downstream, is essential to **geographically diversify our business**, spreading risks and investments across European and non-European markets.

This **international outlook** also helps to get to know and compare different cultural contexts in order to develop **skills that will be useful in a changing, global environment**.

2. Innovating

We are paying increasing attention to **energy saving** and to production strategies and **processes that reduce the impact on the environment**.

This standing innovation approach is on the increase, and will include partnerships with leading schools or with our customers and suppliers, to extend markets and enable new investments.

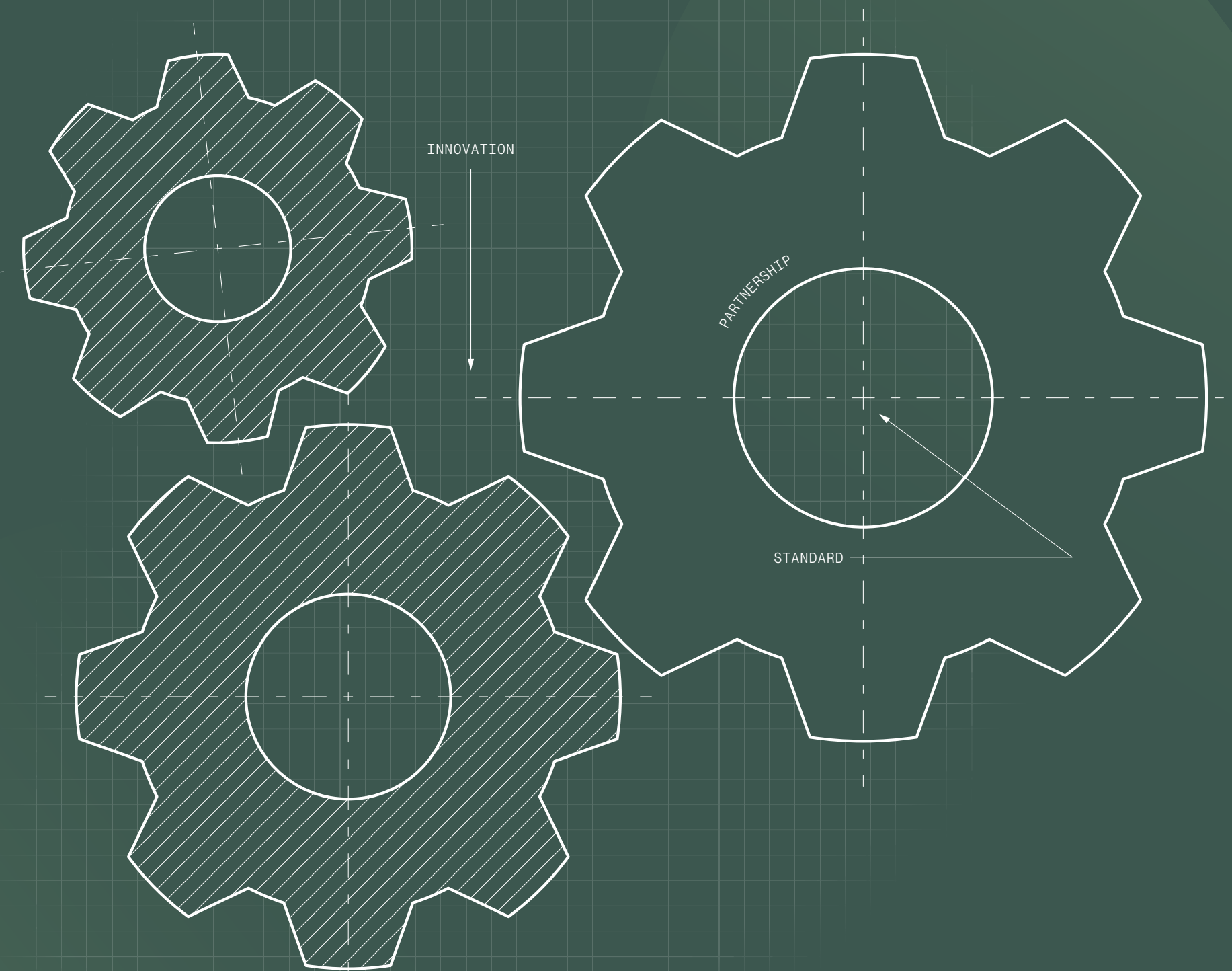

The Research and Development programme is also aiming to respond to new market needs in order to improve production processes, products and services. We want to make them **more effective, more efficient and more environment-friendly**.

3. Reducing our carbon footprint

Reducing our carbon footprint helps to fight **climate change**, and is a responsible way of increasing sales while improving environmental protection.

Calculation of carbon footprint takes into account all sustainability issues, such as reducing energy consumption, transport, waste, circular economy, development of alternative construction systems, etc. Reducing the carbon footprint is part of the European CO2 emissions reduction target (Fit for 55).

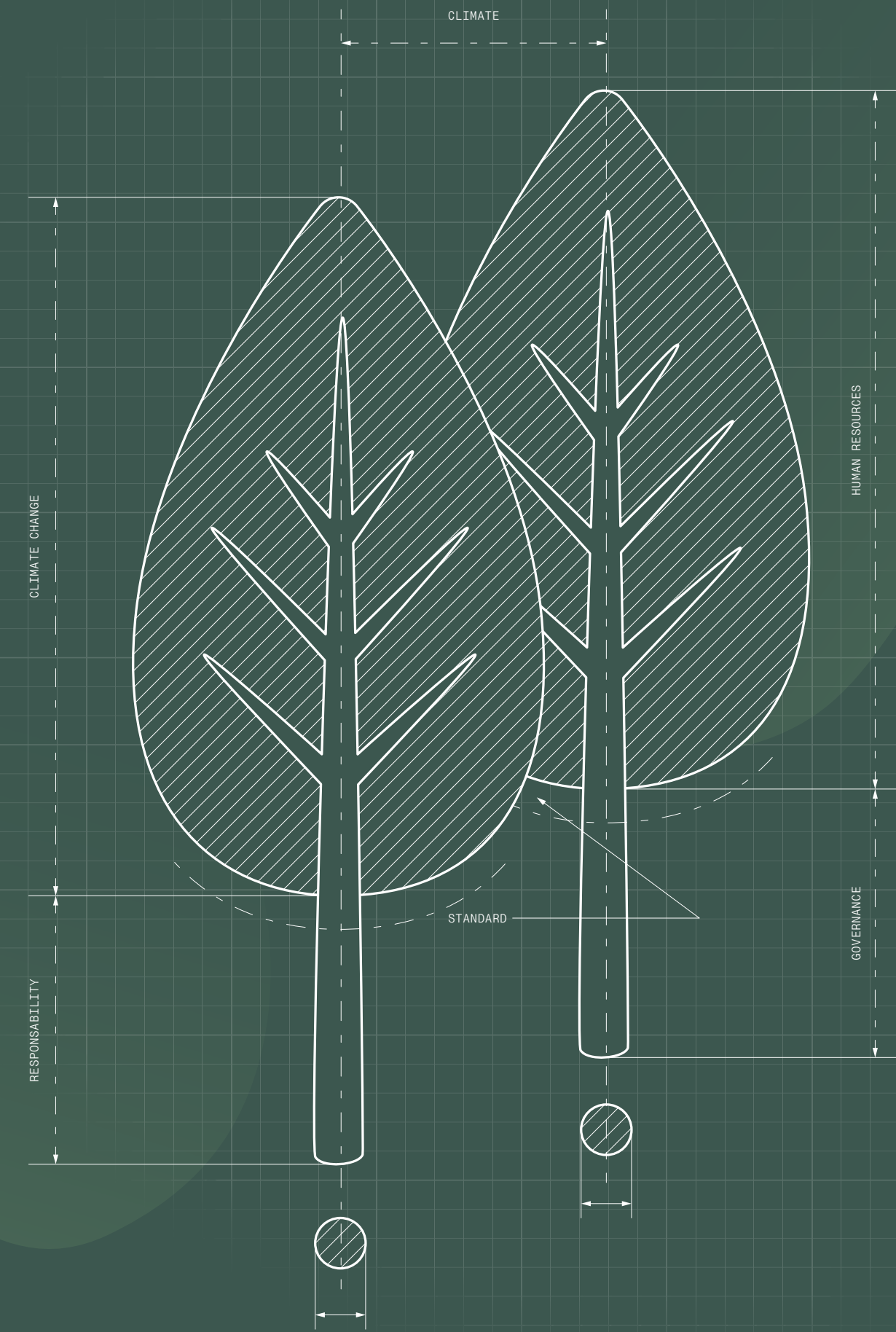

4. Partnership and Territory



Partnership and **collaboration** among industry players are the keys to success in developing RBM in an open, dynamic and adaptive way.

We want to make our partners, customers, suppliers and subcontractors aware of the ecological transition and encourage them to adopt good sustainability practices. In addition, we do not forget the context in which we operate: RBM is **close to the territory and its communities** through concrete support activities and **participation** and **promotion** of social, cultural and sporting initiatives.

5. Developing quality of life in the workplace

Quality of Life in the workplace is crucial if we are to keep our teams motivated and healthy over the long term. Our aim is to provide a **safe and stimulating working environment** where everyone can express their individual potential.

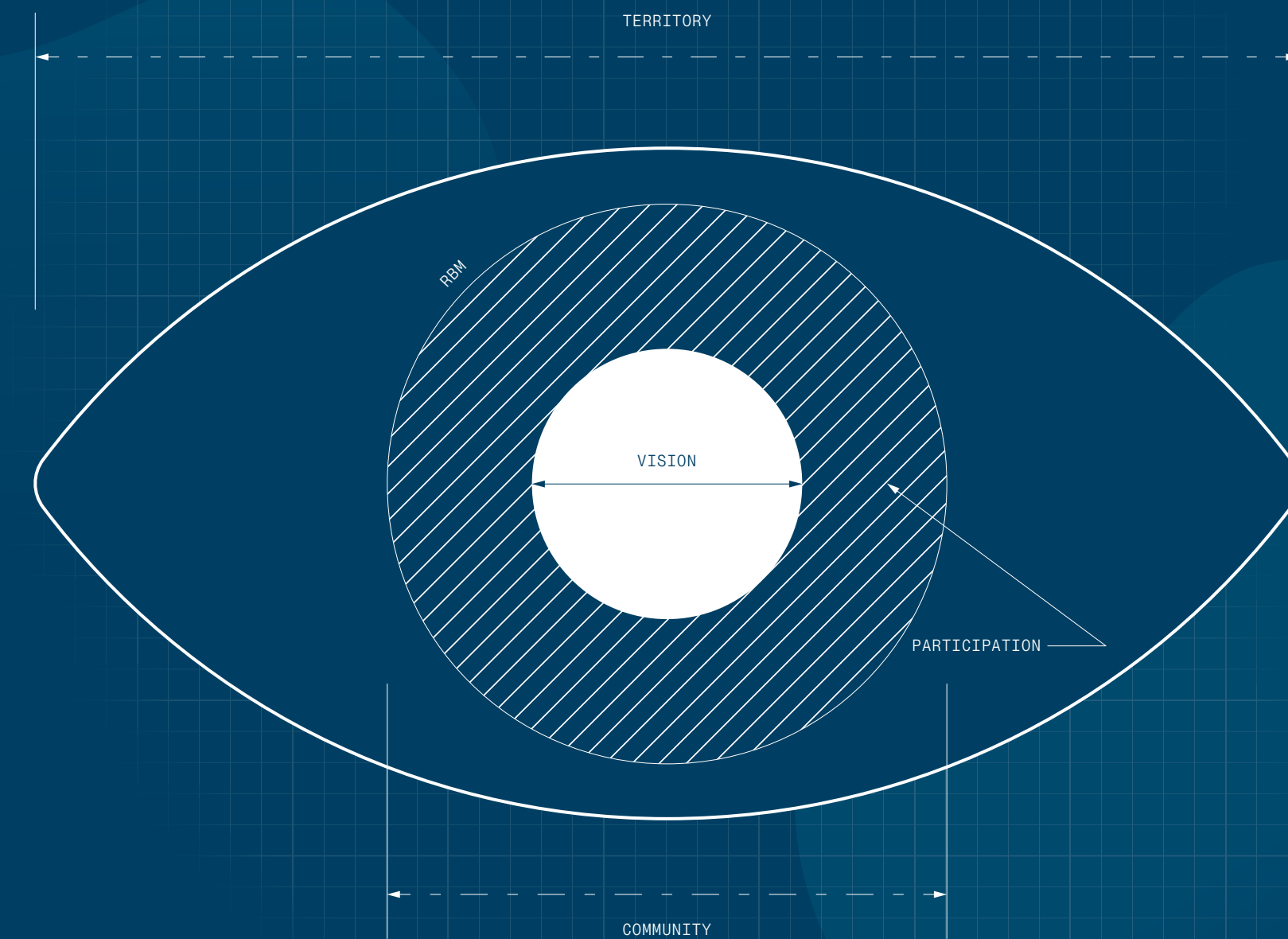

Certifications

PRODUCT CERTIFICATIONS

RBM components are manufactured and tested in accordance with the main current regulations and standards.

In addition, there is the guarantee of product certifications obtained at an international level.

COMPANY CERTIFICATIONS

Quality management system - UNI EN ISO 9001

RBM has held UNI EN ISO 9001 certification since 1992, issued by ICIM and recognized by leading organizations in Italy and worldwide.

Gender equality - UNI PDR 125:2022

In November 2024, RBM obtained the UNI PDR 125:2022 certification on Gender Equality, which is part of a more complex journey towards sustainability that RBM has undertaken with ever-increasing commitment.





RBM S.p.A

Via S. Giuseppe, 1
25075 Nave (BS) - Italy

Tel. +39 030 2537211
info@rbm.eu
rbm.eu | rbmmore.com

