



Rev. 04/2017

DIRTERM / DIRTERM MAG

Self-cleaning dirt separators.

DIRTERM / DIRTERM MAG

Self-cleaning dirt separators.

- +** Removes any impurity
- Ensures system efficiency
- Self-cleaning
- Magnetic*
- Bi-directional.



PRODUCTION RANGE - SELF-CLEANING DIRT SEPARATOR

Code	Size	Connections	Type
2829.04.00	1/2"	F UNI-EN-ISO 228	Dirterm
2829.05.00	3/4"	F UNI-EN-ISO 228	Dirterm
2829.06.00	1"	F UNI-EN-ISO 228	Dirterm
2829.07.00	1"1/4	F UNI-EN-ISO 228	Dirterm
2829.08.00	1"1/2	F UNI-EN-ISO 228	Dirterm
2829.09.00	2"	F UNI-EN-ISO 228	Dirterm
On request	Ø 22	Copper compression pipe	Dirterm
On request	Ø 28	Copper compression pipe	Dirterm



PRODUCTION RANGE - SELF-CLEANING MAGNETIC DIRT SEPARATOR

Code	Size	Connections	Type
3173.04.00	1/2"	F UNI-EN-ISO 228	Dirterm Mag
3173.05.00	3/4"	F UNI-EN-ISO 228	Dirterm Mag
3173.06.00	1"	F UNI-EN-ISO 228	Dirterm Mag
3173.07.00	1"1/4	F UNI-EN-ISO 228	Dirterm Mag
3173.08.00	1"1/2	F UNI-EN-ISO 228	Dirterm Mag
3173.09.00	2"	F UNI-EN-ISO 228	Dirterm Mag
On request	Ø 22	Copper compression pipe	Dirterm Mag
On request	Ø 28	Copper compression pipe	Dirterm Mag



DESCRIPTION

PURPOSE

The **RBM Dirterm** dirt separator series is used to remove the dirt inside the fluids circulating in heating and cooling systems.

The continuous, constant action of these devices helps to eliminate impurities inside the system (sand - sludge - iron oxides - etc. ...) as well as to ensuring a more efficient operation thereof, reducing failures and malfunctions, with consequent advantages for the user in terms of:

- Energy consumption reduction
- Maintenance work reduction
- System management cost reduction

Unlike traditional filters, **Dirterm** dirt separators feature reduced head losses, the ability to separate and remove much smaller particles, and a lower frequency of filtering mesh cleaning operations, besides being self-cleaning (just open the purge valve to remove accumulated dirt, even with the system running).

In addition, **Dirterm Mag** is equipped with a powerful magnet to capture particles such as **rust and sand that are formed due to corrosion and scale** during the normal operation of a system.

OPERATING PRINCIPLE

Through their effective, constant action, **Dirterm** and **Dirterm Mag**

collects all the impurities present in the system (resulting both from decantation and the collision with the inner grid), preventing them from circulating within it, thus avoiding wear and damage of all the components making up the system.

Dirt separators may allow the elimination of very small-sized particles that traditional purification filters are not able to eliminate.

Maintenance operations are quick and very easy: the impurities stopped by the filter are accumulated on its bottom as long as the opening of the specific discharge valve allows the expulsion thereof.

CAUTIONS

In order to function properly, the dirt separator must be installed in a **vertical position (on horizontal pipes)**, with the impurity drain valve facing downwards.

WARNINGS

Dirterm Mag contains a powerful magnet, and strong magnetic fields are present within the filter.

We recommend the holders of pacemaker devices to keep at a safe distance during the filter operation and / or maintenance.

CONSTRUCTION FEATURES

Body	Brass CW 617N UNI EN 12165
Elastomers used	EPDM and NBR
Cartridge	AISI 304 stainless steel
Magnet (series 3173 only)	Neodymium
Connections	F UNI-EN-ISO-228 / Compression connection for copper pipe (depending on version)

TECHNICAL FEATURES

Usable fluid	Water Water + Glycol 30%
Maximum fluid temperature	110 °C
Maximum operating pressure	10 Bar (1000 kPa)

DIMENSIONAL FEATURES

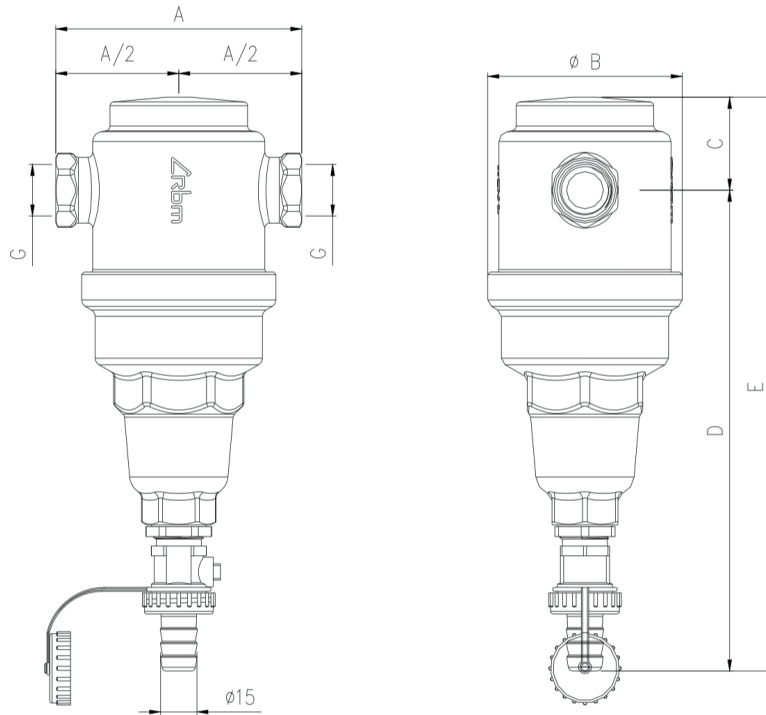

Code	G	A [mm]	Ø B [mm]	C [mm]	D [mm]	E [mm]
2829.04.00	1/2"	100	79	37,5	194	231,5
2829.05.00	3/4"	105	79	37,5	194	231,5
2829.06.00	1"	110	79	37,5	194	231,5
2829.07.00	1"1/4	115	79	37,5	194	231,5
2829.08.00	1"1/2	120	88	47	201	248
2829.09.00	2"	125	88	47	201	248
On request	Ø 22	125	79	37,5	194	231,5
On request	Ø 28	130	79	37,5	194	231,5

Code	G	A [mm]	Ø B [mm]	C [mm]	D [mm]	E [mm]
3173.04.00	1/2"	100	79	37,5	188	225,5
3173.05.00	3/4"	105	79	37,5	188	225,5
3173.06.00	1"	110	79	37,5	188	225,5
3173.07.00	1"1/4	115	79	37,5	188	225,5
3173.08.00	1"1/2	120	88	47	197	244
3173.09.00	2"	125	88	47	197	244
On request	Ø 22	125	79	37,5	188	225,5
On request	Ø 28	130	79	37,5	188	225,5

FLUID DYNAMICS FEATURES

Flow rate diagram - pressure drop

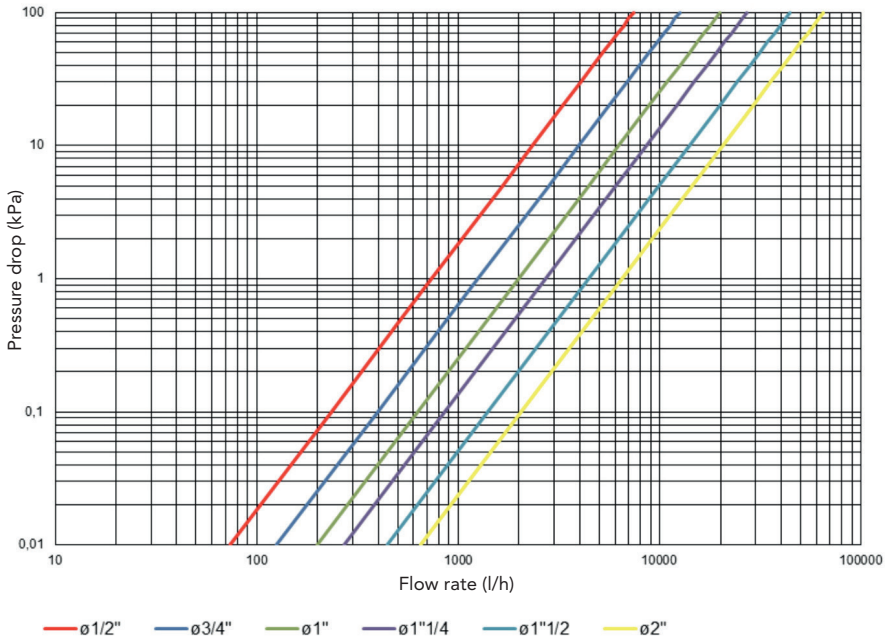

Size	Kv [m ³ /h]
1/2"	7,40
3/4" - ø22	12,66
1" - ø28	20,44
1 1/4"	28,14
1 1/2"	44,45
2"	65,58

STRENGTHS / WORKING PRINCIPLE

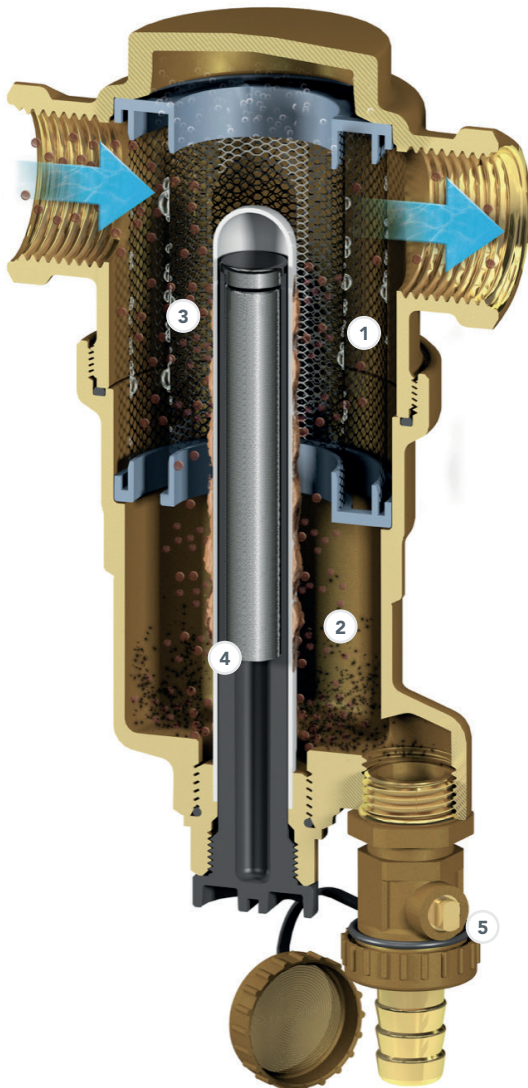

RBM Dirterm and **Dirterm Mag** dirt separators feature a very solid structure, in which we can distinguish:

- A decantation chamber
- An internal cartridge (the new **RBM 3-layer** cartridge)
- An accumulation area.

1 DECONTINATION CHAMBER

(A sudden section increase slows down the inflow). Structure made of brass.

2 ACCUMULATION AREA

Large and very far from the flow passage, resulting in less frequent maintenance work.

3 INNOVATIVE RBM 3-layer CARTRIDGE

Made up of 3 stainless steel sheets with different filtering grades. Stainless steel is an outstanding guarantee of durability and maximum reliability under varying pressure and temperature conditions. With respect to any other possible choice, this is certainly the one with greater resistance to corrosion and wear generated by impurities (whose nature is less and less predictable).

Designed to minimise the possibility of impurities running through, it offers little resistance to the flow passage (characterised by very small head loss). It does not hamper the dirt descent into the accumulation area, so dirt particles do not risk being carried away by the flow running towards the dirt separator outlet.

4 MAGNET

(Only available in the Dirterm Mag device series 3173)
Powerful magnet to capture particles such as rust and sand that are formed due to corrosion and scale during the normal operation of a system.

5 PURGE VALVE

Adjustable, with hose connector and safety cap.

INSTALLATION GUIDE

- It is recommended to install **Dirterm** and **Dirterm Mag** on the primary circuit return (**boiler inlet**) and in any case upstream of the devices that it must protect (circulators, exchangers, etc. ...). To allow subsequent maintenance work, make sure there is enough space around **Dirterm** and **Dirterm Mag**;
- Empty the system and locate the return pipe. We suggest cutting the pipe by providing a suitable template for the size of the cut to be performed. Refer to the "Dimensional Features" section of this technical sheet to identify the exact length of the pipe to be cut (see the size indicated in Table A);
- Install **shut-off valves** upstream and downstream of the filter, in order to allow scheduled maintenance work and filter cleaning to be performed;
- Install **Dirterm** and **Dirterm Mag** making sure that all connections are properly aligned. **Dirterm** and **Dirterm Mag** are **bi-directional components**, therefore they have the same efficiency irrespective of the direction of the flow running through them. Screw the discharge valve to the bottom of the filter;
- In order to function properly, the dirt separator must be installed in a **vertical position (on horizontal pipes)**, with the impurity drain valve facing downwards.

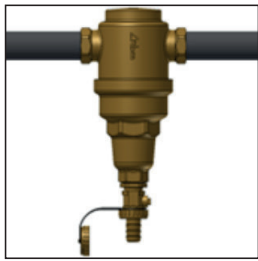

OK

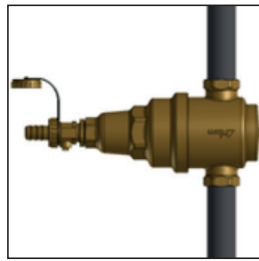

NO

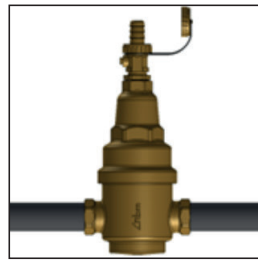

NO

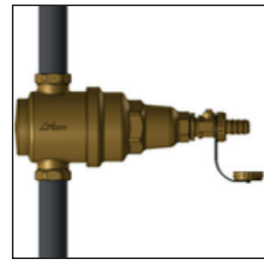

NO

- After completing the installation, make sure that there are no water leaks or other leakage with the shut-off valves fully open.

MAINTENANCE GUIDE

ROUTINE MAINTENANCE:

Filter purging can be performed with the system running, acting on the ball valve provided with hose connection. It is important **to perform the purge operation at least once a year**. In case of first application, perform the first purge after a month.

EXTRAORDINARY ROUTINE:

To properly clean and service **Dirterm** and **Dirterm Mag** (filtering cartridge cleaning), follow the steps described below:

- Intercept the filter through the ball valves located upstream and downstream of the filter itself
- Unscrew the filter lower body (should high temperature fluid circulate in the circuit, use the necessary precautions and safety devices to avoid direct contact with the fluid)
- Remove the RBM 3-layer filtering cartridge and wash it under running water; possibly replace it if it is damaged
- Place the cartridge in the filter lower body and screw it to the filter upper body - Carefully reposition the sealing ring in its place
- Re-open the ball valves upstream and downstream of the filter to open the hydraulic system

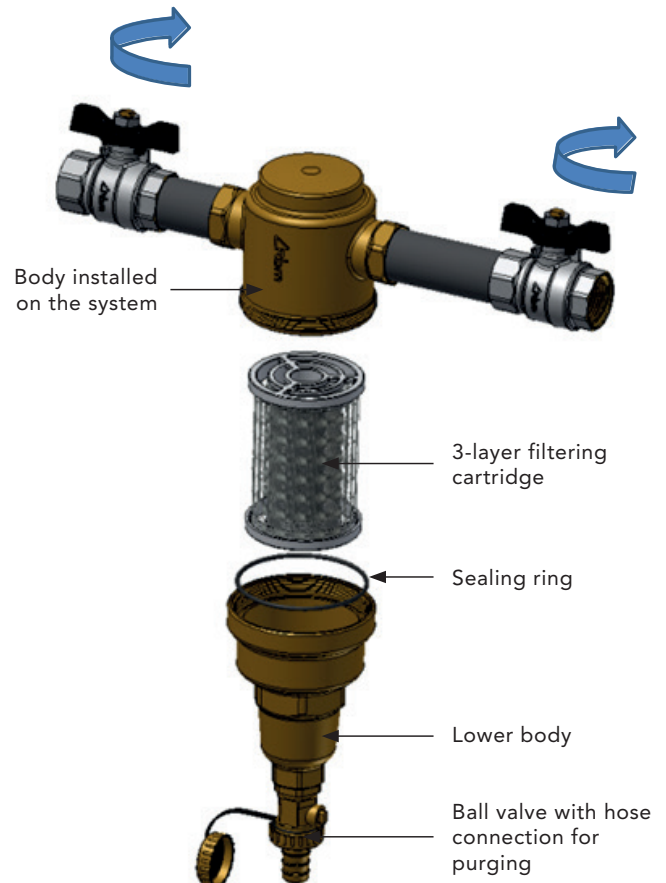

SPECIFICATION ITEMS

SERIES 2829

Filter for self-cleaning dirt separator model **Dirterm**, complete with discharge ball cock with hose connection. Brass body. AISI 304 steel 3-layer filtering cartridge. EPDM hydraulic seals. Threaded connections FF UNI-EN-ISO 228 (or compression ones for copper pipe). Maximum operating pressure 10 Bar. Maximum operating temperature 110 °C. Available sizes 1/2" ÷ 2" (or compression for copper pipe ø22 and ø28).

SERIES 3173

Filter for self-cleaning magnetic dirt separator model **Dirterm Mag**, complete with discharge ball cock with hose connection. Brass body. AISI 304 steel 3-layer filtering cartridge. EPDM hydraulic seals. Neodymium magnet. Threaded connections FF UNI-EN-ISO 228 (or compression ones for copper pipe). Maximum operating pressure 10 Bar. Maximum operating temperature 110 °C. Available sizes 1/2" ÷ 2" (or compression for copper pipe ø22 and ø28).

RBM spa reserves the right to improve and change the described products and related technical data at any moment and without prior notice: always refer to the instructions attached with the supplied components; this sheet is an aid, should the instructions be extremely schematic. Our technical department is always at your disposal for any doubt, problem or clarification.

RBM Spa

Via S. Giuseppe, 1 • 25075 Nave (Brescia) Italy
Tel 030 2537211 • Fax 030 2531798 • info@rbm.eu • www.rbm.eu

 @rbmspa  RBM S.p.A.  rbm_spa_  Rbm Italia